

HIGH SPIN INDUSTRIAL WASHER EXTRACTOR

16kg

**SPARE PARTS MANUAL
ERSATZTEIL-KATALOG**

**CATALOGUE DES ACCESSORIES
CATÁLOGO DE PIEZAS DE REPUES**

**SP508893 F
Publication date: 12 Jun 2014**

PREFACE

Original or identical parts must be used for replacement in the machine. After servicing replace secure all panels in original way and keep this manual in a secured place for future reference.

When calling or writing about your machine, be sure to mention type, model and serial number. Model, type and serial number are located on name plate on rear of the machine or on the last manual page.

The manufacturer reserves himself the right to change the specifications of manual at any time, without previous notice. The data and presentation are given only for information.

Please note that it regards only general information, since it is impossible to give in the manual the complete survey of all specific details on all the machines included in our line.

The spare parts manual is for machines with capacity 16 kg / 35 lbs as from serial number 16F011428RP.

Machine design:

- with coinmeter, marked (coin), or without coinmeter
- OPL - the version controlled by push-buttons without coinmeter marked (OPL)
- heating: electrical, steam

CONTENTS

SP508898B Frame and tub support	7
SP508900C Cabinet	9
SP533019A Control panel Easy Control, Graphitronic	11
SP527556 Coinmeter	13
SP504356F Soap hopper and top cover	15
SP508897C Door lock	17
SP533021 Soap hopper, water system	19
SP533020A Rear panel	21
SP504362B Drive	25
SP532984 Box of electrical components	27
SP508895D Wash drum and tub	29
SP507447C Round door	31
SP528602B Square door	33
SP508896A Trunnion	35
SP513203 Wet cleaning	37

INTRODUCTION

Pour changer les pièces détachées de la machine il faut utiliser les pièces d'origines ou anciennes. Après une intervention de service, mettez tous les panneaux dans un état original et laissez ce mode d'emploi dans un endroit à l'abri pour les informations éventuelles.

Si vous téléphonez ou écrivez en ce qui concerne votre machine, indiquez toujours le type, modèle et numéro de série de la machine. Le type, modèle et le numéro de série de la machine sont indiqués sur la palquette indicatrice sur le derrière de la machine ou sur la page dernière du mode d'emploi.

Le fabricant se réserve le droit de réaliser les changements des spécifications qui sont indiquées dans le catalogue à tout moment et sans avertissement antérieur. Toutes les données ne sont que informatives. Prenez en compte s.v.p. que ce catalogue ne concerne que les données informatives, parce que il n'est pas possible d'indiquer la liste complète de tous les détails de toutes nos machines de notre production.

Ce catalogue est valable pour les machines avec la capacité 16 kg / 35 lbs.

CONTENU

SP508898B Chassis et la fixation du tambour	7
SP508900C Carénage	9
SP533019A Panneau de controle	11
SP527556 Système d'accepteur de pièces	13
SP504356F Le bac à poudre et couvercle supérieure	15
SP508897C Serrure de la porte	17
SP533021 Tuyau et la soupape d'écoulement	19
SP533020A Panneau arrière	21
5SP04362B Entraînement	25
SP532984 Panneau d'appareillage	27
SP508895D Tambour laveur externe et interne	29
SP507447C Porte ronde	31
SP528602B Porte angulaire	33
SP508896A Moyeu	35
SP513203 Nettoyage par voie humide	37

VORWORT

Für einen Austausch an der Waschmaschine müssen Original- oder ursprüngliche Teile verwendet werden. Nach einem Serviceeingriff sämtliche Paneels im ursprünglichen Zustand absichern, und dieses Handbuch an einer sicheren Stelle für eventuelle Informationen aufbewahren.

Falls Sie telefonieren oder schreiben betreffs Ihre Maschine, immer den Typ, das Modell und Seriennummer angeben.

Typ, Modell und Seriennummer sind an dem Herstellschild an den Maschinenhinterseite angeführt, oder an der Handbuchhinterseite.

Der Hersteller behält sich das Recht vor, jederzeit und ohne irgendwelche vorherige Bekanntmachung Änderungen von Spezifikationen, in diesem Katalog angeführt, vorzunehmen. Sämtliche Angaben sind lediglich informativ.

Nehmen Sie, bitte, zur Kenntnis, daß dieser Katalog lediglich allgemeine Informationen betrifft, da es nicht möglich ist, eine komplette Übersicht aller Details über sämtliche Maschinen unserer Produktion anzuführen.

Der Katalog ist für Maschinen mit einer Kapazität von 16 kg / 35 lbs.

ÍNDICE

SP508898B Bastidor y sujeción del tambor.....	7
SP508900C Capotaje.....	9
SP533019A Control panel	11
SP527556 Sistema del autómeta de monedas.....	13
SP504356F Tolvas de detergentes y tapa superior	15
SP508897C Cerradura de puerta.....	17
SP533021 Manguera y válvula de descarga	19
SP533020A Panel trasero	21
SP504362B Propulsión	25
SP532984 Panel de herramientas	27
SP508895D Tambor interior y exterior de lavar	29
SP507447C Puerta redonda	31
SP528602B Puerta anclada.....	33
SP508896A Ajuste del cubo	35
SP513203 Sistema la limpieza húmeda.....	37

INTRODUCCIÓN

Para un recambio en la máquina deben usarse las piezas originales. Después de la intervención de servicio, hay que asegurar todos los paneles al estado primordial y poner este Manual a un cierto lugar para servirle de información eventual.

Si usted telefonea o escribe con respecto a su máquina, sírvase siempre indicar el tipo, modelo y número de serie.

El tipo, modelo y número de serie están indicados en el rótulo de fabricación que está fijado en la parte posterior de la máquina o en la parte posterior del Manual.

El fabricante cuando quiera, sin previo aviso se reserva el derecho de modificar las especificaciones que están indicadas en este catálogo. Todos los datos son sólo informativos.

Sírvase dar cuenta de que este catálogo se refiere sólo a las informaciones generales, porque es imposible indicar un sumario completo de todos los detalles sobre todas las máquinas de nuestra fabricación.

El presente catálogo está destinado para las máquinas con capacidad de 16 kg / 35 lbs

INHALT

SP508898B Rahmen und Trommelbefestigung	7
SP508900C Haube.....	9
SP533019A Steuerung	11
SP527556..... Münzgerätsystem.....	13
SP504356F..... Oberdeckel und Waschmittelfüllbehälter.....	15
SP508897C Türschloß.....	17
SP533021..... Schlauch und Ablassventil	19
SP533020A Hintertafel	21
SP504362B Antrieb	25
SP532984..... Gerätetafel	27
SP508895D Außen- und Innenwaschtrommel.....	29
SP507447C Tür runde	31
SP528602B Tür eckige	33
SP508896A Nabenlagerung.....	35
SP513203..... Nasse Reinigung.....	37

FRAME AND TUB SUPPORT

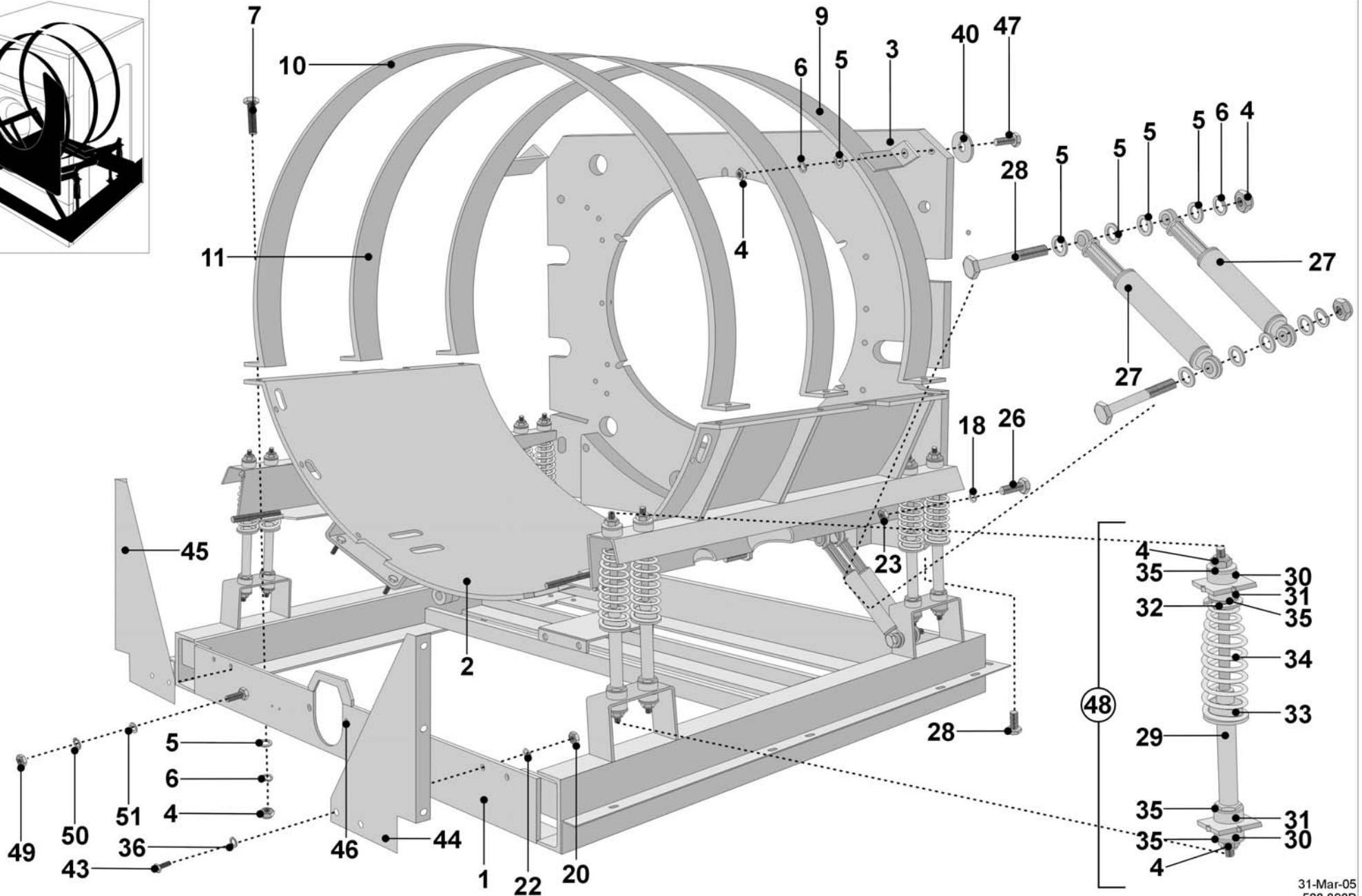
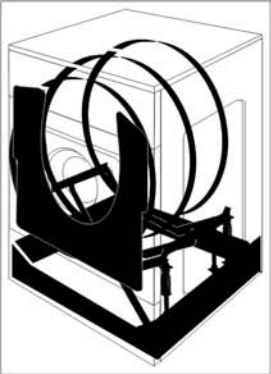

Frame and tub support: drawing nr. 508898B

1	SP509587	Frame	Support	Ständer	Soporte
2	SP522362	Tub bed	Mise du tambour	Trommelbett	Cama del tambor
3	SP528540	Counter weight complete	Poids avancé complete	Vordergewicht kompl.	Contrapeso delantero completo
4	SPPRI228000003	Nut selflocking M10	Contr-écrou M10	Mutter selbstsichernd M10	Tuerca de autoseguridad M10
5	SPPRI231000031	Washer 22x11x3	Rondelle 22x11x3	Unterlegscheibe 22x11x3	Arandela 22x11x3
6	SPPRI245000025	Spring washer M10	Rondelle élastique M10	Federscheibe M10	Arandela elástica M10
7	SPPRI202003035	Bolt M10x50	Vis M10x50	Schraube M 10 x 50	Tornillo M10x50
9	SP512016	Sliding ring front	Anneau avancé	Vorderring	Anillo delantero
10	SPF01100003114	Sliding ring rear	Bague de friction arriere	Hinterer Reibungsring	Anillo de fricción posterior
11	SPF01106000114	Sliding ring middle	Anneau central	Mittelring	Anillo central
18	SPPRI245000009	Spring washer M16	Rondelle élastique M16	Federscheibe M16	Arandela elástica M16
20	SPPRI226000009	Nut M8	Ecrou M8	Mutter M8	Tuerca M8
22	SP311127000008	Washer 8	Rondelle 8	Unterlegscheibe 8	Arandela 8
23	SP310934000016	Nut M16	Ecrou M16	Mutter M16	Tuerca M16
26	SPPRI202000053	Bolt M16x40	Vis M16x40	Schraube M16x40	Tornillo M16x40
27	SPPRI611000025	Shock absorber	Amortisseur	Dämpfer	Amortiguador
28	SPPRI202000038	Bolt M10x80	Vis M10x80	Schraube M10x80	Tornillo M10x80
29	SPPRI611001025	Spring leg	Tige	Zugstange	Tirante
30	SPPRI611007025	Black round rubber B	Anneau caoutchouc supérieur B	Gummiring B	Anillo de goma B
31	SPPRI611008025	Black round rubber A	Anneau caoutchouc supérieur A	Gummiring A	Anillo de goma A
32	SPPRI611036025	Upper spring holder	Selle supérieur	Obersitz	Asiento superior
33	SPPRI611035025	Lower spring holder	Selle base	Sitz unten	Asiento inferior
34	SPPRI611028025	Spring -red	Ressort - rouge	Feder - rot	Resorte - rojo
35	SPPRI611009025	Washer	Rondelle	Unterlegscheibe	Arandela
36	SPPRI231000021	Washer 8,4x24x2	Rondelle 8,4x24x2	Unterlegscheibe 8,4x24x2	Arandela 8,4x24x2
40	SPPRI231000040	Washer 40x12x3	Rondelle 40x12x3	Unterlegscheibe 40x12x3	Arandela 40x12x3
43	SPPRI202001028	Bolt M8x40	Vis M8x40	Schraube M8x40	Tornillo M8x40
44	SPF01100006014	Panel holder left	Manette droite de carrosserie	Paneelhalter R	Sujetador del panel derecho
45	SPF01100005914	Panel holder right	Manette gauche de carrosserie	Paneelhalter L	Sujetador del panel izquierdo
46	SPPRI125000020	Riveting nut M6	Ecrou de rivetage M6	Nietmutter M6	Tuerca de remache M6
47	SP309933001030	Bolt M10x30	Vis M10x30	Schraube M10x30	Tornillo M10x30
48	SP510899	Shock absorber complete	Amortisseur complete	Dämpfer komplett	Amortiguador compl.
49	SP310934240008	Nut M8	Ecrou M8	Mutter M8	Tuerca M8
50	SP311125240008	Washer 8	Rondelle 8	Unterlegscheibe 8	Arandela 8
51	SP311679824008	Washer M8	Rondelle M8	Unterlegscheibe M8	Arandela M8

CABINET

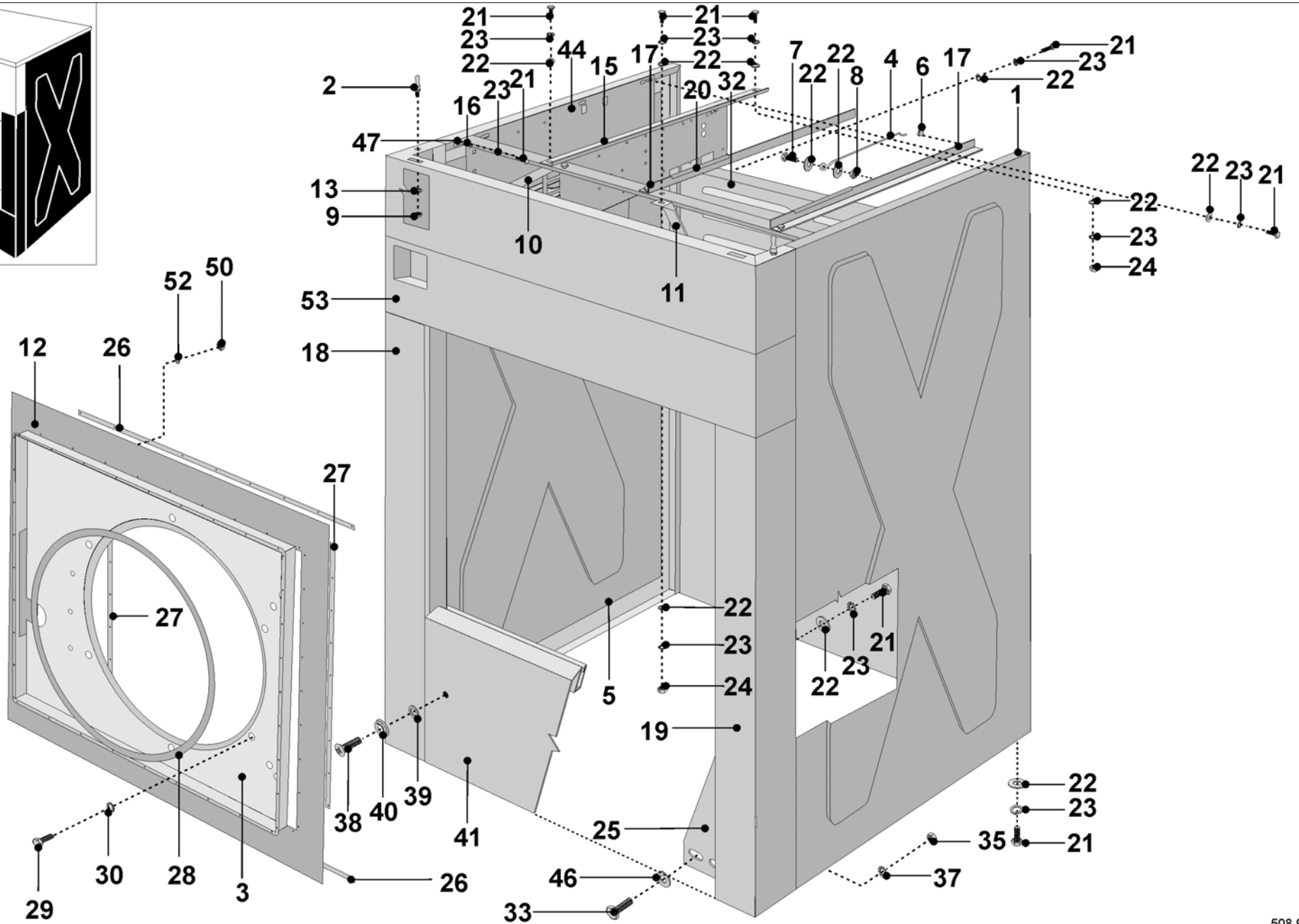

Cabinet: drawing nr. 508900C

1	SP512013	Side panel right, stainless steel	Panneau droit lateral	Seitentafel rechts	Cubierta lateral derecha
1	SP533627	Side panel right, painted grey			
1	SP512014	Side panel left, stainless steel	Panneau gauche lateral	Seitentafel links	Cubierta lateral izquierda
1	SP533626	Side panel left, painted grey			
2	SPPRI611000023	Bolt	Vis	Schraube	Tornillo
3	SP528538	Cover complete-round door	Couvercle complet – la porte ronde	Abdeckung komplett – runde Tür	Cubierta completa – puerta redonda
3	SP528546	Cover complete- square door	Couvercle complet – la porte angulaire	Abdeckung komplett – eckige Tür	Cubierta completa – puerta anclada
4	SPPRI610000078	Support top panel	Etai du couvercle supérieur	Strebe Oberdeckel	Soporte de tapa superior
5	SP100850	Isolation	Isolation	Isolierung	Aislamiento
6	SPPRI551016250	Self sticking cable clip	Support autocollant du cable	Selbstklebender Kabelhalter	Sujetador autoadhesivo del cable
7	SP309933000630	Bolt M6x30	Vis M6x30	Schraube M6x30	Tornillo M6x30
8	SPPRI228000001	Nut selfstopping M8	Contre-écrou M8	Mutter M8 selbstsichernd	Tuerca de autoseguridad M8
9	SPPRI226000005	Nut M5	Ecrou M5	Mutter M5	Tuerca M5
10	SP509596	Right reinforcement	Renfort droite	Versteifung R	Refuerzo derecho
11	SP509597	Left reinforcement	Renfort gauche	Versteifung L	Refuerzo izquierdo
12	SP509532	Rubber	Joint	Dichtung	Junta
13	SPPRI245000003	Washer with external teeth M5	Rondelle à crans multiples du bord ext. M5	Fächerscheibe M5	Arandela en abanico M5
15	SPF011111002114	Holder contactor box	Poutre du tableau des appareils	Träger Gerätetafel	Viga del panel de instrumentos
16	SPF011111002214	Cross holder	Poutre transversale	Querträger	Viga transversal
17	SPF011111002314	Holder soap hopper	Support de la trémie	Halter Füllbehälter	Soporte
18	SP533630	Left front cover complete	Couvercle AV complet gauche	Vorderabdeckung L komplett	Cubierta delantera izquierda completa
19	SP533628	Right front cover complete	Couvercle AV complet droite	Vorderabdeckung R komplett	Cubierta delantera derecha completa
20	SPPRI505000058	Rubber strip	Ruban en caoutchouc	Gummiband	Cinta de goma
21	SP309933000616	Bolt M6x16	Vis M6x16	Schraube M6x16	Tornillo M6x16
22	SP311734900006	Washer M6	Rondelle M6	Unterlegscheibe M6	Arandela M6
23	SP311127240006	Washer M6	Rondelle M6	Unterlegscheibe M6	Arandela M6
24	SPPRI2260000007	Nut M6	Ecrou M6	Mutter M6	Tuerca M6
25	SP517348	Left front holder of cabinet	Support du capotage avant gauche	Gehäusehalter vorne links	Soporte de la cubierta frontal izquierda
25	SP517349	Right front holder of cabinet	Support du capotage avant droit	Gehäusehalter vorne rechts	Soporte de la cubierta frontal derecha
26	SP509451	Strip I	Bande I	Band I	Cinta I
27	SP509450	Strip	Bande	Band	Cinta
28	SPPRI505000058	Profile seal	Joint profilé	Profildichtung	Empaquetadura perfilada
29	SP309966240410	Bolt M4x10	Vis M4x10	Schraube M4x10	Tornillo M4x10
30	SPPRI247000003	Washer M5	Rondelle M5	Unterlegscheibe M5	Arandela M5
32	SP517352	Rear panel complete	Panneau arrière	Rückwand	Panel Trasero
32	SP517351	Rear panel complete for steam heating	Panneau arrière variateur de fréquence	Frequenz Rückwand	Panel Trasero frecuencia
33	SPPRI202000019	Bolt M8x25	Vis M8x25	Schraube M8x25	Tornillo M8x25
35	SPPRI226000009	Nut M8	Ecrou M8	Mutter M8	Tuerca M8
37	SP311127000008	Washer 8	Rondelle 8	Unterlegscheibe 8	Arandela 8
38	SPPRI212010034	Bolt M6x50 steel	Vis M6x50 Inox	Schraube M6x50 rostfrei	Tornillo M6x50 inoxidable
39	SPPRI521002001	Washer	Rondelle	Unterlegscheibe	Arandela
40	SPPRI247000001	Washer M6	Rondelle M6	Unterlegscheibe M6	Arandela M6
41	SP533632	Service panel complete	Panneau de service	Schaltbrett Edelstahl	Panel Servicio inox
44	SP100682	Box of electrical components	Panneau d'appareillage	Gerätetafel	Panel de herramientas
46	SPPRI231000021	Washer 8	Rondelle 8	Unterlegscheibe 8	Arandela 8
47	SPPRI232000002	Washer 6	Rondelle 6	Unterlegscheibe 6	Arandela 6
50	SP310934000004	Nut M4	Ecrou M4	Mutter M4	Tuerca M4
52	SP311127000004	Washer M4	Rondelle M4	Unterlegscheibe M4	Arandela M4
53	SP533653	Additional panel, stainless steel, Easy Control, Graphitronic			
53	SP533654	Additional panel for coinmeter, stainless steel, Easy Control			
53	SP533655	Additional panel for wet cleaning, stainless steel, Graphitronic			

CONTROL PANEL EASY CONTROL, GRAPHITRONIC

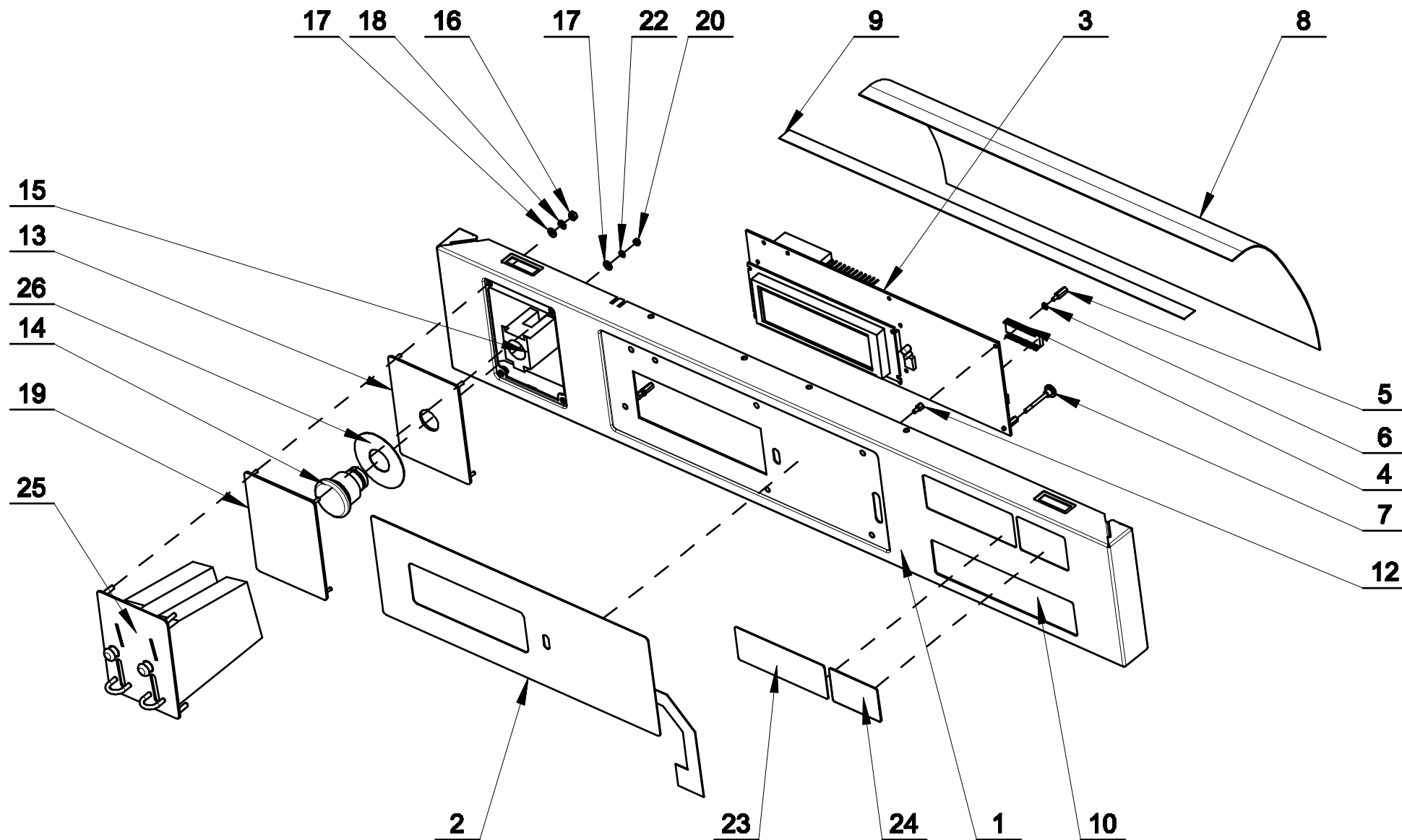

Control panel Easy Control, Graphitronic: drawing nr. 533019A

1	SP534199	Control panel Easy control, painted grey			
1	SP534200	Control panel Easy control, painted black			
1	SP534186	Control panel Graphitronic, painted grey			
1	SP534189	Control panel Graphitronic, painted black			
2	SP516745	Keyboard Graphitronic, grey			
2	SP525905	Keyboard Graphitronic, black			
2	SP527273	Keyboard Easy Control, grey			
2	SP527274	Keyboard Easy Control, black			
2	SP527276	Keyboard Easy Control, Tecnitramo			
3	SP526008	Programmer board Graphitronic, version MC5 FC			
3	SP526004	Programmer board Easy control, version MC5 EC			
4	SP526001	Memory			
5	SP102127	Spacer M3x12x7			
6	SP311679824003	Washer M3			
7	SP101041	Knurled thumb screw with collar M3x30			
8	SPPRI543000004	Plastic cover			
9	SP510846	Adhesive tape reversible			
10	SP529591	Wash symbols label, grey			
10	SP529592	Wash symbols label, black			
12	SP521444	Spacer M3x5x3			
13	SP521701	Label OPL (grey)			
13	SP521702	Label OPL (black)			
14	SP102259	Emergency stop button			
15	SP102260	Contact block			
16	SP310934000004	Nut M4			
17	SP311125000004	Washer M4			
18	SP311679800004	Lock washer external teeth M4			
19	SP101266	Logo label (grey)			
19	SP101267	Logo label (black)			
20	SP310934000003	Nut M3			
22	SP311679800003	Washer M3			
23	SP534351	Name plate grey			
23	SP532265	Name plate black			
24	SP534372	Insert label 16 kg, grey			
24	SP534377	Insert label 16 kg, black			
24	SP534388	Insert label 17kg			
25	-	Coinmeter, (according to the order)			
26	SPPRI551005248	Label of emergency stop button			
-	SPPRI229000004	Square nut in cage M6, (applicable for coinmeter, not shown)			
-	-	Wash programmes label, (according to language, not shown)			
-	SP309084000410	Bolt M4, (not shown)			

COIN METER SYSTEM

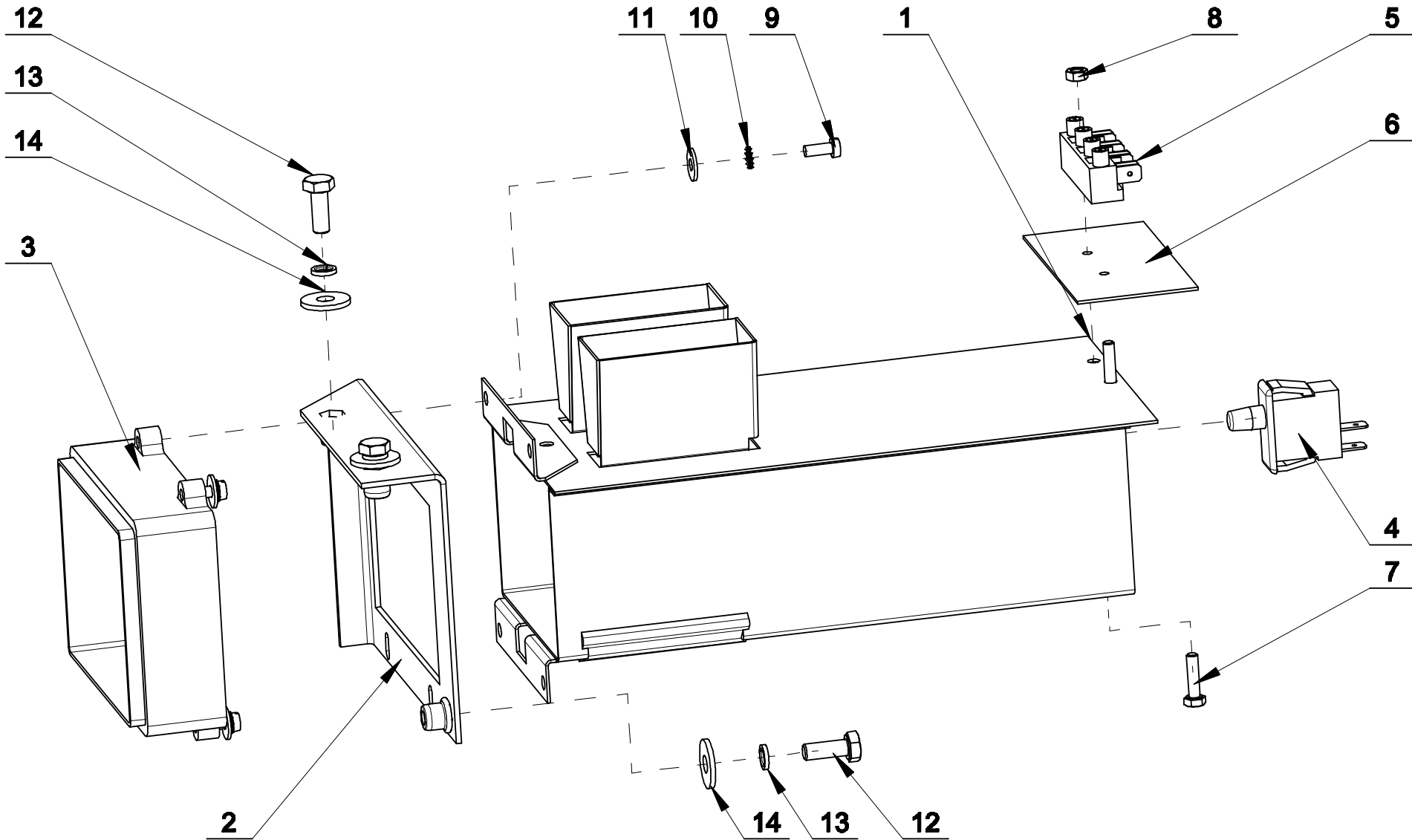

Coin meter system: drawing nr. 527556

1	SP515381	Coin vault	Boîte à monnaies	Münzgerät	Automata de monedas
2	SP517353	Coin vault holder complete	Support monnayeur	Münzengeräthalter	Sujetador del monedero
3	SP501514	Ornamental plate coin vault	Cadre monnayeur	Münzgerätrahmen	Marco del monedero
4	SP506045	Coin vault switch, not applicable			
5	SPPRI350000007	Terminal board 4-poles	Réglette de bornes à 4-pôles	Klemmleiste 4-polig	Panel de bornes de 4 polos
6	SPPRI350012007	Isolation paper	Papier isolant	Isolationspapier	Papel de aislamiento
7	SP309933000416	Bolt M4x16	Vis M4x16	Schraube M4x16	Tornillo M4x16
8	SP310934000004	Nut M4	Écrou M4	Mutter M4	Tuerca M4
9	SP309084000410	Bolt M4x10	Vis M4x10	Schraube M4x10	Tornillo M4x10
10	SP311679800004	Washer 4,3	Rondelle 4,3	Unterlegscheibe 4,3	Arandela 4,3
11	SP311902100004	Washer 4,3	Rondelle 4,3	Unterlegscheibe 4,3	Arandela 4,3
12	SP309933000616	Bolt M6x16	Vis M6x16	Schraube M6x16	Tornillo M6x16
13	SP311127000006	Washer 6	Rondelle 6	Unterlegscheibe 6	Arandela 6
14	SP311902100006	Washer 6	Rondelle 6	Unterlegscheibe 6	Arandela 6

SOAP HOPPER AND TOP COVER

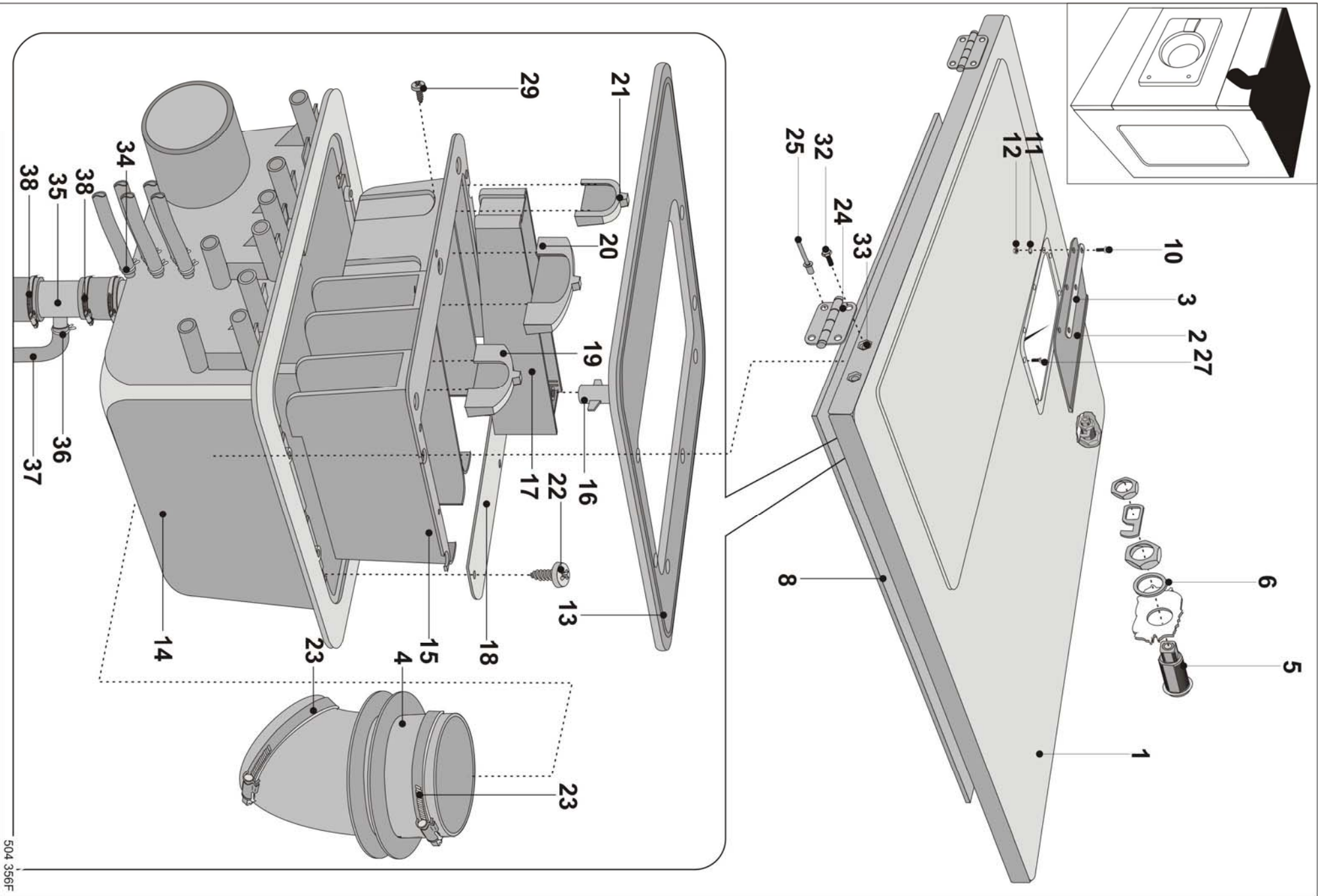

Soap hopper and top cover: drawing nr. 504356F

1	SP521826	Top panel inox complete	Panneau supérieur inox	Deckel Edelstahl	Panel superior inox
1	SP521837	Top panel inox	Panneau supérieur inox	Deckel Edelstahl	Panel superior inox
2	SPPRI505038027	Rubber cover soap hopper	Chapeau de la trémie	Deckel Füllbehälter	Tapita de la tolva
3	SPF01121000214	Lath for rubber cover soap hopper	Liteau	Leiste	Listón
4	SP101981	Rubber soap hopper-tub	Coude de la trémie	Kniestück Füllbehälter	Acodadura de la tolva
5	SPPRI610000007	Lock top panel	Serrure du couvercle	Schloß Deckel	Cerradura de la tapa
5		Large nut lock, part of No. 5	Grand écrou, partie de la position 5	Mutter groß, Positionsbestandteil 5	Tuerca grande, parte de la posición 5
5		Hook lock short, part of No. 5	Encliquetage, partie de la position 5	Klinke, Positionsbestandteil 5	Trinquete, parte de la posición 5
5		Little nut lock, part of No. 5	Petit écrou, partie de la position 5	Mutter klein, Positionsbestandteil 5	Tuerca pequeña, parte de la posición 5
6	SPPRI522000012	Washer	Rondelle	Unterlegscheibe	Arandela
8	SP100850	Rubber anti-vibration foil	Feuille en caoutchouc contre-vibrations	Gummi-Antivibrationsfolie	Lamina antivibratoria de goma
10	SPPRI211000033	Bolt M4x12	Vis M4x12	Schraube M4x12	Tornillo M4x12
11	SP311127240004	Spring washer M4 steel	Rondelle élastique M4 Inox	Federscheibe M4 rostfrei	Arandela elástica M4 inoxidable
12	SP310934240004	Nut M4 steel	Ecrou M4 Inox	Mutter M4 rostfrei	Tuerca M4 inoxidable
13	SPPRI505039027	Rubber cover soap hopper	Joint de la trémie	Dichtung Füllbehälter	Empaquetadura de la tolva
14	SPPRI505040027	Outer part soap hopper	Corps de la trémie	Körper Füllbehälter	Cuerpo de la tolva
15	SPPRI505041027	Inner part soap hopper	Cale de la trémie	Einsatz Füllbehälter	Componente-cubeta de la tolva
16	SPPRI505043027	Syphon part last rinse	Rouleau	Zylinder	Cilindro
17	SPPRI505042027	Box last rinse	Chambre de la trémie	Kammer Füllbehälter	Cámara de la tolva
18	SPPRI505044027	Protection plate	Couvercle	Deckel	Tapa
19	SPPRI505045027	Drawer prewash	Ecran - prelavage	Blende - Vorwäsche	Barrera - prelavado
20	SPPRI505046027	Drawer main wash	Ecran - lavage	Blende - Waschvorgang	Barrera - lavado
21	SPPRI505047027	Insertion piece last rinse	Ecran - rincage final	Blende - Endspülen	Barrera - enjuague final
22	SPPRI215000006	Bolt 3,5x9	Vis 3,5x9	Schraube 3,5x9	Tornillo 3,5x9
23	SPPRI240000005	Hose clamp	Agrafe de tuyau	Schlauchschelle	Abrazadera de manguera
24	SP516832	Hinge	Penture	Türband	Suspensión
25	SP313250004075	Rivet 4x6	Rivet 4x6	Niet 4x6	Remache 4x6
27	SPPRI212002020	Bolt M5x16	Vis M5x16	Schraube M5x16	Tornillo M5x16
29	SP309797240265	Bolt	Vis auto-filetage	Schraube selbstschneidend	Tornillo autorroscante
32	SP521957	Bolt M4x12	Vis M4x12	Schraube M4x12	Tornillo M4x12
33	SP313251002104	Riveting nut M4	Ecrou de rivetage M4	Nietmutter M4	Tuerca de remache M4
34	SPPRI241000001	Clip d14 - 14,5	Agrafe d14 - 14,5	Schelle d14 - 14,5	Borne d14 - 14,5
35	SP522119	T-part 90°	T - pièce 90°	T-Stück 90°	T - pieza 90°
36	SP526134	Clip d18,5-19,5	Agrafe d18,5-19,5	Schelle d18,5-19,5	Borne d18,5-19,5
37	SP522200	Hose d14/18	Tuyau d14/18	Schlauch d14/18	Manguera d14/18
38	SPPRI240000003	Clip d14 - 14,5	Agrafe d14 - 14,5	Schelle d14 - 14,5	Borne d14 - 14,5

DOOR LOCK

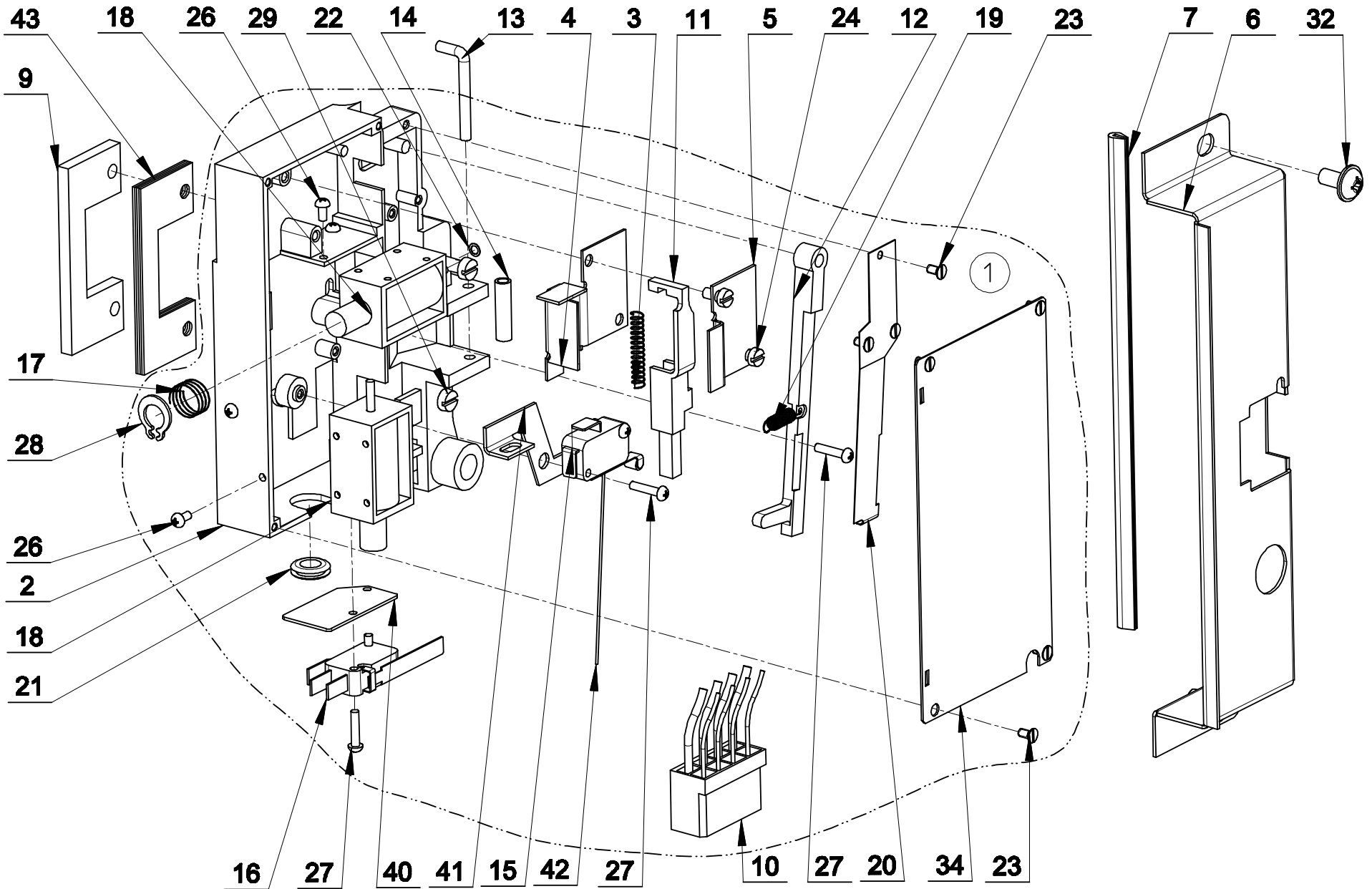

Door lock: drawing nr. 508897C

1	SP509473	Door lock complete	Serrure complète	Schloß komplett	Cerradura completa
2	SPPRI610000132	Door lock	Serrure	Schoß	Cerradura
3	SP223116000214	Door lock spring			
4	SP223116000324	Decoupling plate	Cude de guidage	Führungswürfel	Cubo quiador
5	SP223116000424	Decoupling plate	Cude de guidage	Führungswürfel	Cubo quiador
6	SP509406	Door lock cover	Couvercle du verrou	Schlossabdeckung	Cubierta del cierre
7	SPPRI505000058	Profiled sealing	Garniture d'étanchéité profilée	Profildichtung	Junta del perfil
9	SP527395	Washer	Rondelle	Unterlegscheibe	Arandela
10	SP524742	Door lock wiring, MCB EC	Bloc serrure MCB EC	Schloßrangier MCB EC	Haz de conductores de la cerradura MCB EC
11	SPPRI610000087	Small lock hook	Serrure	Schloßklinke klein	Pestillo de la cerradura pequeño
12	SPPRI610000134	Locking handle part	Tige de commande	Abschlußzugstange	Tirante de cierre
13	SPPRI610000090	Lock spindle	Cliquet	Sperre	Cierre
14	SPPRI610000091	Lock tube	Rouleau	Zylinder	Rodillo
15	SPPRI610032077	Microswitch	Microrupteur	Mikroshalter	Microinterruptor
16	SPPRI610011077	Microswitch	Microrupteur	Mikroshalter	Microinterruptor
17	SPPRI611000050	Spring coil	Ressort bobine	Federspule	Resorte de la bobina
18	SPPRI610012077	Electromagnetic coil	Bobine électro-magnétique	Elektromagnetische Spule	Bobina electromagnética
19	SPPRI611000048	Door lock spring			
20	SPPRI611000047	Leaf spring	Support	Federstütze	Apoyo elástico
21	SPPRI501000069	Cable bushing	Manchon pour câbles électriques	Kabeldurchführung	Atravesador de cable
22	SPPRI230000007	Washer 5,1x3,3x0,1	Rondelle 5,1x3,3x0,1	Unterlegscheibe 5,1x3,3x0,1	Arandela 5,1x3,3x0,1
23	SP309963240306	Bolt M3x6	Vis M3x6	Schraube M3x6	Tornillo M3x6
24	SP309084000408	Bolt M4x8	Vis M4x8	Schraube M4x8	Tornillo M4x8
26	SP309798500306	Bolt M3x6	Vis M3x6	Schraube M3x6	Tornillo M3x6
27	SP309798500314	Bolt M3x14	Vis M3x14	Schraube M3x14	Tornillo M3x14
28	SPPRI242000013	Securing ring	Bague de blocage	Sicherungsring	Anillo de seguridad
29	SP309084000530	Bolt M5x30	Vis M5x30	Schraube M5x30	Tornillo M5x30
32	SP309595240612	Bolt M6x12	Vis M6x12	Schraube M6x12	Tornillo M6x12
34	SP520325	Door lock cover	Couvercle du verrou	Schlossabdeckung	Cubierta del cierre
40	SP101154	Isolation washer	Coussin d'isolation	Isolierunterlegscheibe	Arandela aisladora
41	SPPRI610000135	Emergency opening lever	Bras de commande	Zugstange	Tirante
42	SPPRI723000004	Emergency opening cord	Tirant de déblocage	Zugstange des Notöffnens	Tirante de la abertura de emergencia
43	SP527396	Washer	Rondelle	Unterlegscheibe	Arandela

SOAP HOPPER, WATER SYSTEM

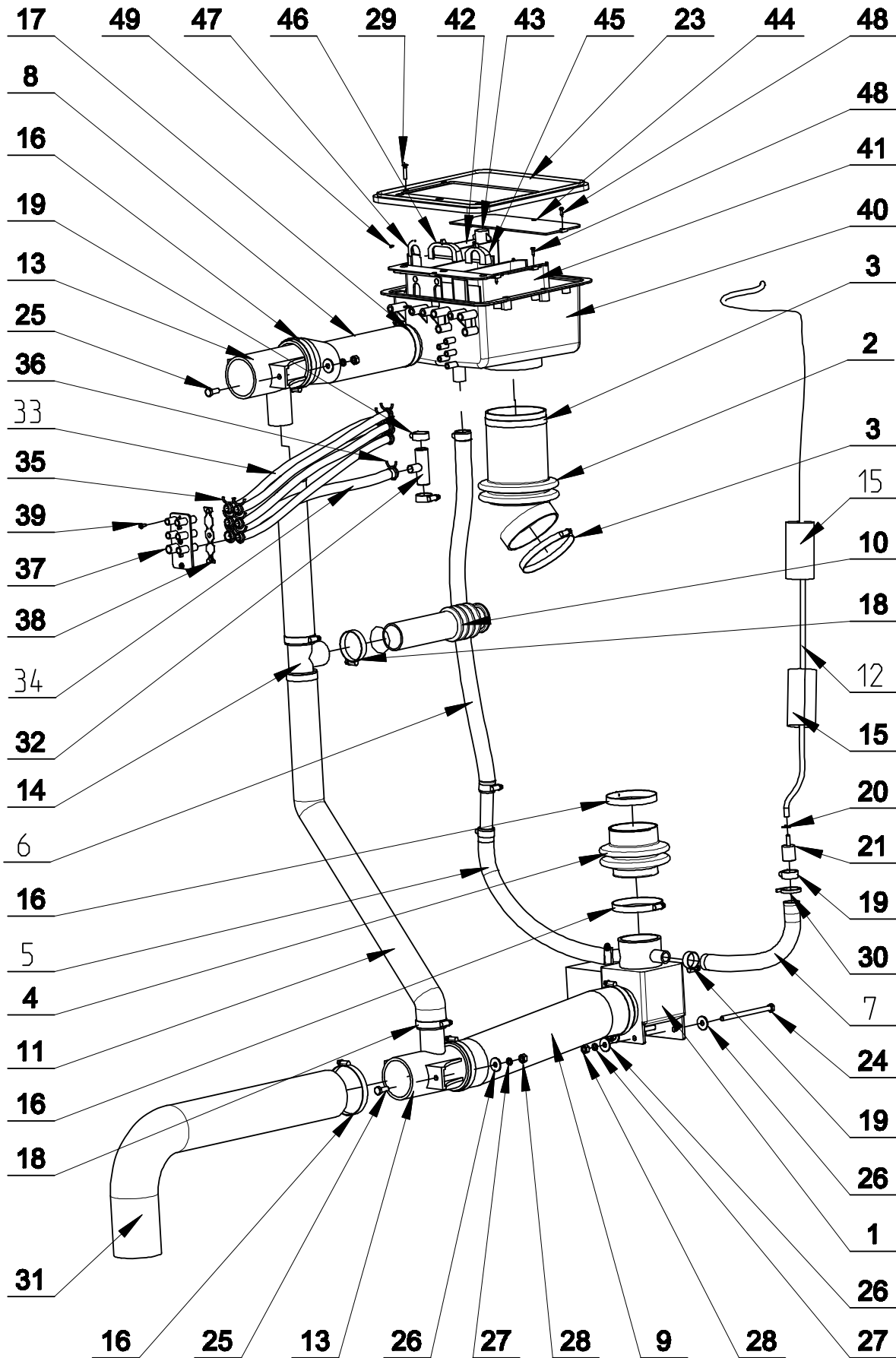

533021

Soap hopper, water system: drawing nr. 533021

1	SPPRI340055051	Drain valve complete, (PRI340054051 + PRI340002051)	Soupape d'évacuation complète	Ablassventil kompl.	Válvula de descarga completa
-	SPPRI340054051	Drain valve chamber	Chambre de la soupape d'évacuation	Kammer Ablassventil	Cámara valvular de la válvula de descarga
-	SPPRI340002051	Drain valve motor with gearbox	Moteur de la soupape d'évacuation	Motor Ablassventil	Motorcito de la válvula de descarga
2	SP101981	Hose soap hopper - tub			
3	SPPRI240000005	Hose clamp			
4	SP273124080161	Tub-outlet valve hose			
5	SPPRI503002049	Hose			
6	SPPRI503002049	Hose			
7	SPPRI503002049	Air trap hose			
8	SPPRI505000089	Air vent-soaphopper hose			
9	SPPRI505000087	Drain hose			
10	SPPRI505000088	Air vent-backplate hose			
11	SPPRI505000090	Overflow hose			
12	SPPRI540001003	Water level switch hose			
13	SPPRI505000078	T-part			
14	SPPRI505000077	T-part			
15	SP100188	Foam rubber aquastate			
16	SPPRI240000007	Hose clamp			
17	SPPRI240000021	Hose clamp			
18	SPPRI240000017	Hose clamp			
19	SPPRI240000003	Hose clamp			
20	SPPRI241000017	Hose clamp			
21	SPPRI503000027	Air trap reduction			
23	SPPRI505039027	Soaphopper sealing			
24	SP309931008120	Bolt M8x120			
25	SP309933000820	Bolt M8x20			
26	SP311902100008	Washer 8			
27	SP311127000008	Washer 8			
28	SP310934000008	Nut M8			
29	SPPRI212002020	Bolt M5x16			
30	SP503817	Binding strip			
31	SP519463	Drain elbow			
32	SP522119	T-part 90°			
33	SPPRI540020005	Hose			
34	SP522200	Hose			
35	SP526133	Hose clamp			
36	SP526134	Hose clamp			
37	SP522090	Wall connection 6 hoses			
38	SP526128	Plate with thread			
39	SP510856	Bolt M4x13			
40	SPPRI505040027	External part powder part			
41	SPPRI505041027	Internal part powder part			
42	SPPRI505042027	Small box softener			
43	SPPRI505043027	Cilinder			
44	SPPRI505044027	Protect plate powder box			
45	SPPRI505045027	Slide prewash			
46	SPPRI505046027	Slide mainwash			
47	SPPRI505047027	Slide softener			
48	SP309798124313	Screw ST3,5x13			
49	SP309797240265	Screw ST2,2x6			

REAR PANEL

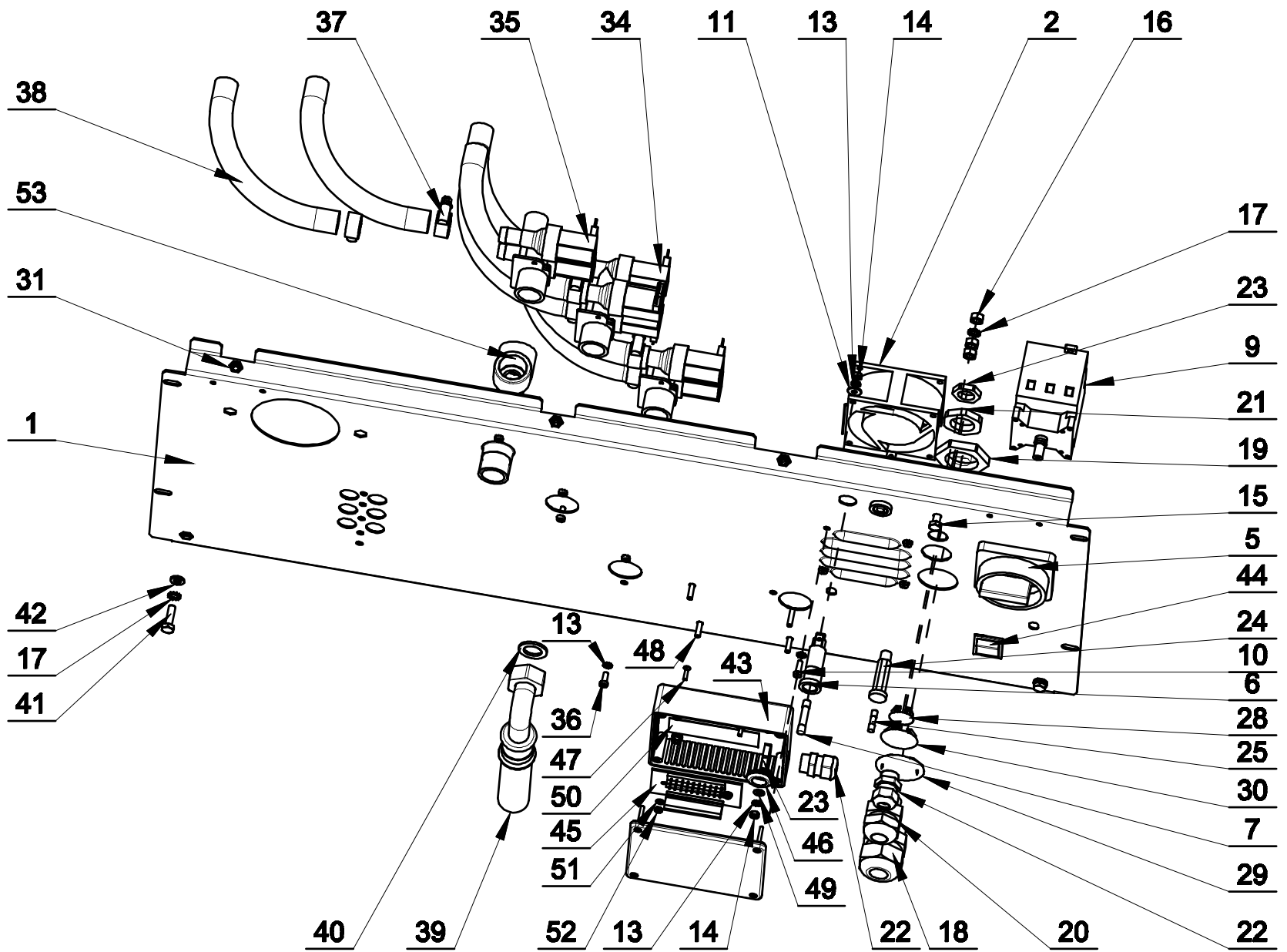

Rear panel: drawing nr. 533020A

1	SP526160	Rear panel			
1	SP526159	Rear panel for wet cleaning			
2	SP337230802050	Ventilator			
5	SPPRI404000095	Main switch knob			
6	SPPRI401003020	Fuse holder			
7	SP345805163032	Fuse 1A			
9	SPPRI404000098	Main switch 32A			
9	SPPRI404000097	Main switch 25A			
9	SPPRI404000099	Main switch 63A			
9	SP506407	Fourth pole of main switch 25A			
9	SPPRI404001098	Fourth pole of main switch 32A			
9	SPPRI404001099	Fourth pole of main switch 63A			
10	SP309084240412	Bolt M4x12			
11	SP311902100004	Washer M4			
13	SP311679800004	Washer with external teeth M4			
14	SP310934000004	Nut M4			
15	SP309933100625	Bolt M6x25			
16	SP310934100006	Nut M6			
17	SP311679824006	Washer with external teeth M6			
18	SP101409	Cable bushing M32			
19	SP101419	Cable bushing nut M32			
20	SP101408	Cable bushing M25			
21	SP101418	Cable bushing nut M25			
22	SP101406	Cable bushing M16			
23	SP101416	Cable bushing nut M16			
24	SPPRI401001020	Fuse holder			
25	SPPRI401022021	Fuse 0,5A			
28	SP345900215120	Plug			
29	SP345900043132	Plug, applicable for steam heating			
30	SP345900032132	Plug, applicable for electrical heating			
31	SP313251000006	Nut M6			
34	SPPRI340030038	Three way valve			
35	SPPRI340020035	Two way valve			
36	SP309084000410	Bolt M4x10			
37	SPPRI240000002	Hose clamp			
38	SPPRI540000014	Inlet hose			
39	SPPRI505000054	Inlet hose, (cold water)			
39	SP101621	Inlet hose, valid for water approval			
39	SP533036	Inlet hose, (hot water)			
40	SPPRI520001009	Rubber packing			
41	SP309933000620	Bolt M6x20			
42	SP311125240006	Washer 6,4			
43	SP534273	Plastic box			
44	SPPRI348000097	Programming switch			
45	SP524714	Terminal board			
46	SP273121013002	Cable bushing			
47	SP309963000312	Bolt M3x12			
48	SP309933000416	Bolt M4x16			
49	SP311125000004	Washer 4,3			
50	SP524740	Electrical connection label			
51	SP311125000003	Washer 3,2			
52	SP310934000003	Nut M3			

DRIVE

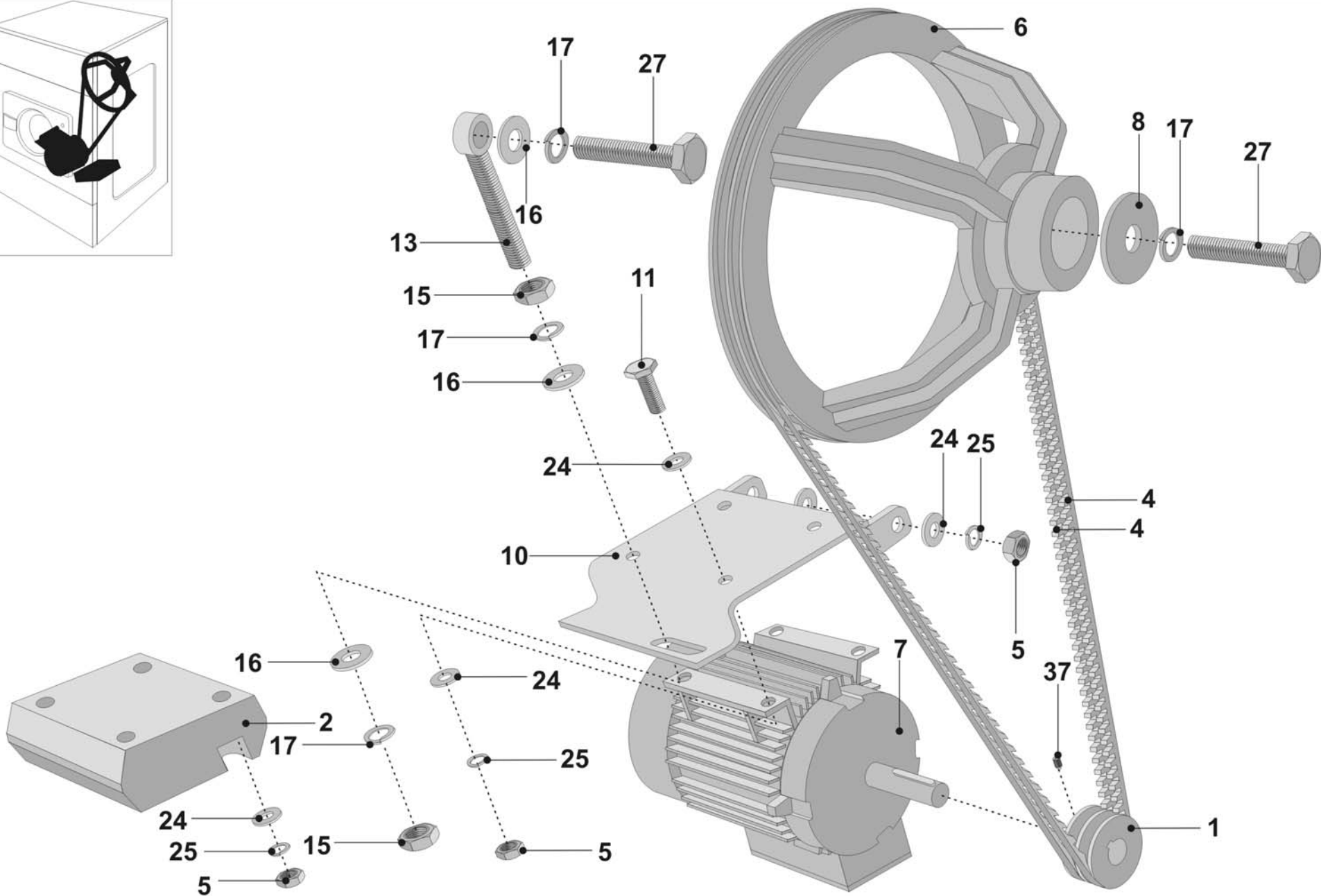

Drive: drawing nr. 504362B

1	SPF06102001913	Motor pulley	Poulie	Riemenscheibe	Polea
2	SPPRI615000057	Counter weight of motor	Poids du moteur	Gewicht Motor	Contrapeso del motor
4	SPPRI607000110	V-belt	Courroie belt II	Keilriemen belt II	Correa achaflanada belt II
5	SP310934000012	Nut M12	Ecrou M12	Mutter M12	Tuerca M12
6	SPF01100005112	Drum pulley	Poulie	Riemenscheibe	Polea
7	SPPRI320000009	Motor 2,2 kW - 220/380V	Moteur 2,2 kW - 220/380V	Motor 2,2 kW - 220/380V	Motor 2,2 kW - 220/380V
8	SPPRI231000049	Washer 17x50x5	Cale 17x50x5	Unterlegscheibe 17x50x5	Arandela 17x50x5
10	SP519445	Motor board	Plaque du moteur	Motorplatte	Placa del motor
11	SP309933001235	Bolt M12x35	Vis M12x35	Schraube M12x35	Tornillo M12x35
13	SP527425	Adjusting bolt	Vis	Einstellschraube	Tornillo
15	SP310934000016	Nut M16	Ecrou M16	Mutter M16	Tuerca M16
16	SP311125000017	Washer 17	Cale 17	Unterlegscheibe 17	Arandela 17
17	SP311127000016	Spring washer M16	Rondelle élastique M16	Federscheibe M16	Arandela elástica M16
24	SPPRI231000031	Washer 12	Rondelle 12	Unterlegscheibe 12	Arandela 12
25	SP311127000012	Spring washer M12	Rondelle élastique M12	Federscheibe M12	Arandela elástica M12
27	SP309933001650	Bolt M16x50	Vis M16x50	Schraube M16x50	Tornillo M16x50
37	SPPRI216010002	Bolt M5	Vis M5	Schraube M5	Tornillo M5
-	SP100555	Motor cable	Câble du moteur	Motorkabel	Cable del motor

BOX OF ELECTRICAL COMPONENTS

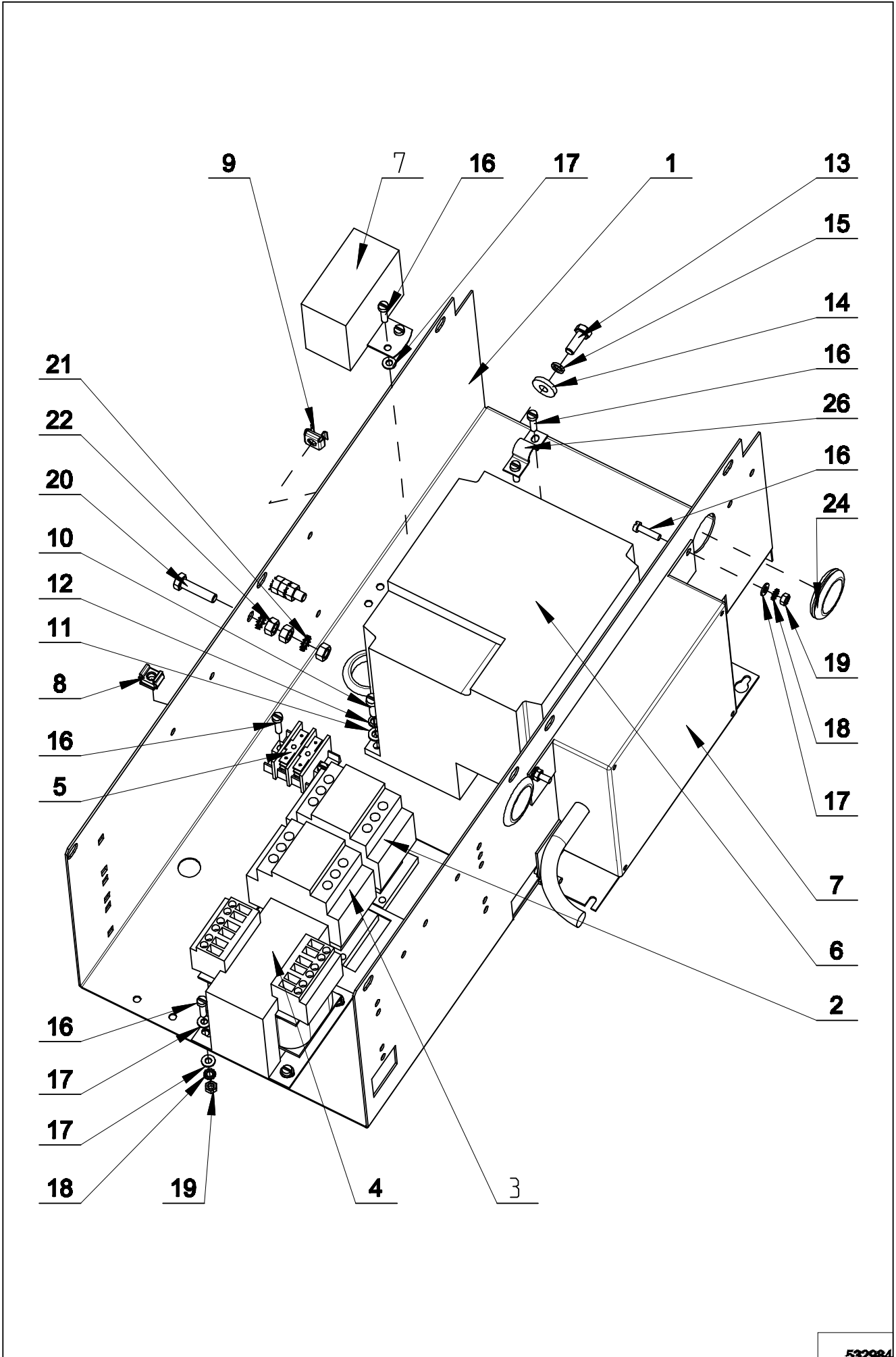

532984

Box of electrical components: drawing nr. 532984

1	SP100682	Box of electrical components			
2	SP514038	Frequency inverter contactor			
3	SP514042	Contacteur, electrical heating LC1-D18			
3	SPPRI345000047	Contacteur, electrical heating LC1-D12			
3	SPPRI345002019	Contacteur, electrical heating LC1-D32			
3	SPPRI345001019	Contacteur, electrical heating LC1-D40			
4	SP516648	Transformer			
5	SPPRI350020007	Terminal board			
6	SP525931	Frequency inverter 1-ph 230V			
6	SP525932	Frequency inverter 3f-400V			
6	SP528235	Frequency inverter fan, (not shown)	Convertisseur de fréquence ventilateur	Frequenzwandler Ventilator	Convertidor de frecuencia, ventilador
7	SP525935	Filter 3f-400V			
7	SP516012	Filter 1ph-230V			
8	SPPRI229000011	Nut M5			
9	SPPRI229000004	Nut M6			
10	SP309084000516	Bolt M5x16			
11	SP311125000005	Washer M5			
12	SP311127000005	Washer M5			
13	SP309933000616	Bolt M6x16			
14	SP311734900006	Washer M6			
15	SP311127000006	Washer M6			
16	SP309084000416	Bolt M4x16			
17	SP311125000004	Washer M4			
18	SP311679800004	Washer with external teeth M4			
19	SP310934000004	Nut M4			
20	SP309933100625	Bolt M6x25			
21	SP311679824006	Washer with external teeth M6			
22	SP310934100006	Nut M6			
24	SPPRI501000071	Cable bushing 25			
26	SPPRI407000091	Holder			
-	SP520055	Main wiring, export Europe, (not shown)			
-	SP528056	Wiring, 3x380-480V without N, export Europe, (not shown)			
-	SP520046	Communication cable, (not shown)			

WASH DRUM AND TUB

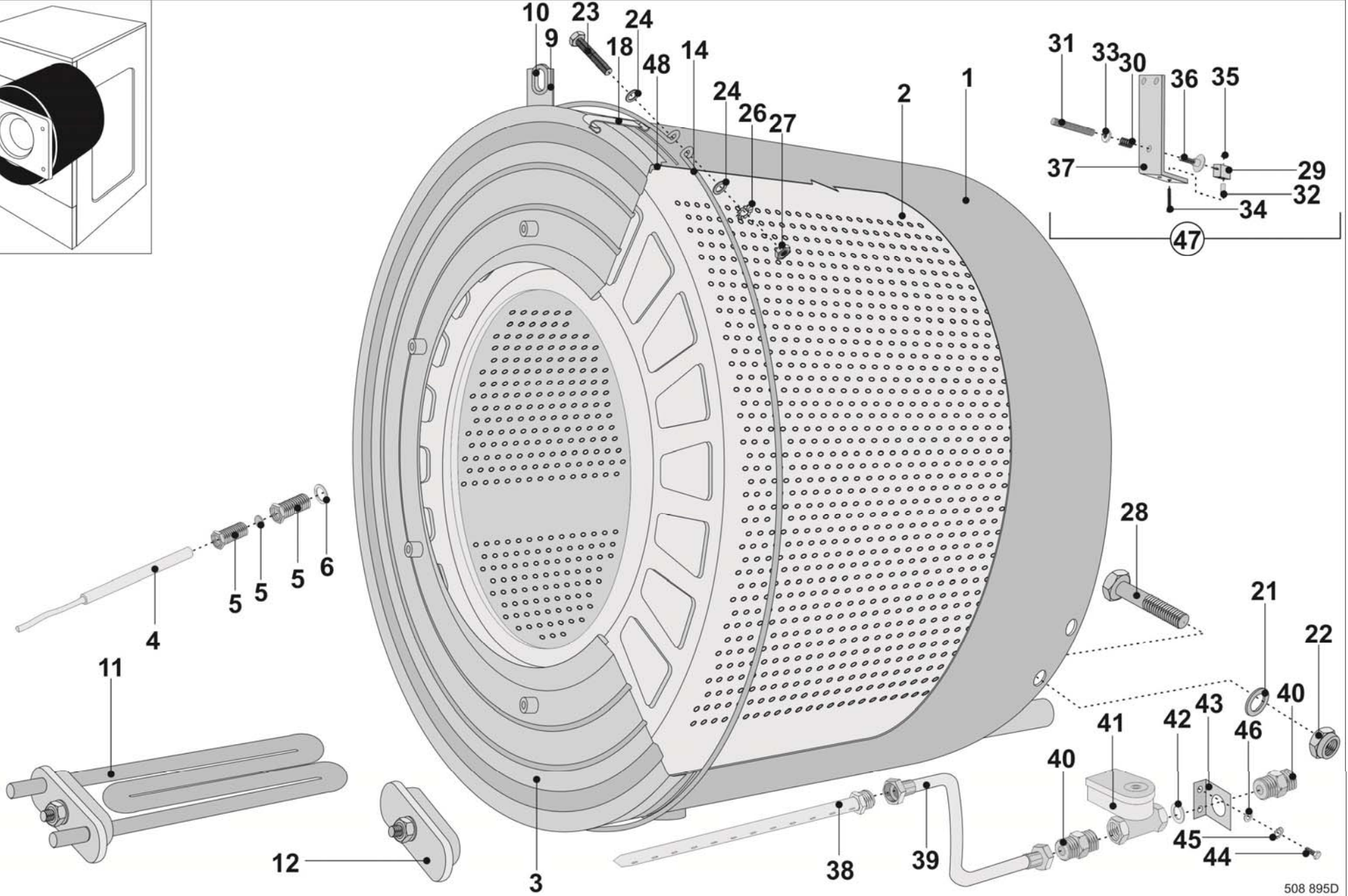
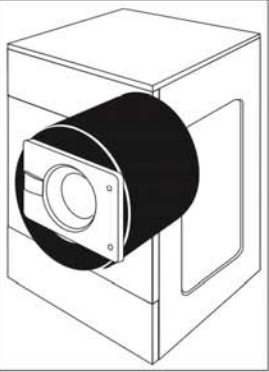

Wash drum and tub: drawing nr. 508895D

1	SPPRI165000019	Tub, (steam heating)	Tambour d'extérieur (chauffage à vapeur)	Außentrommel rostfrei (Dampfheizung)	Tambor exterior inoxidable (calefacción a vapor)
1	SP505395	Tub	Tambour extérieur	Außentrommel	Tambor exterior
2	SP509599	Drum	Tambour d'intérieure	Innentrommel	Tambor interior
3	SP512020	Outer drum front plate complete, including sealing	Face avant du tambour externe complète, garniture incluse	Stirnseite Außentrommel vorne komplett, incl. Dichtung	Cara frontal delantera del tambor completa incluyendo las juntas
4	SPPRI340015019	Temperature sensor	Sonde de température	Temperaturfühler	Sensor de temperatura
5	SPPRI614000047	Holder temperature sensor	Support sonde de température	Gehäuse Temperaturfühler	Soporte sensor de temperatura
6	SPPRI524000001	Ring 14x20x2	Joint 14x20x2	Ring 14x20x2	Anillo 14x20x2
9	SP100178	Holder of tiltswitch	Plaque de détection interrupteur de balourd	Kippschalter Fühlerplatte	Placa detección interruptor basculante
10	SPPRI501001078	Cable passage	Presse-étoupe	Kabeldurchführung	Paso de cable
11	SP540127	Heating body 2x2000W, 220V	Corps de chauffage 2x2000W, 220V	Heizkörper 2x2000W, 220V	Calefactor 2x2000W, 220V
11	SP540132	Heating body 6000W, 220V	Corps de chauffage 6000W, 220V	Heizkörper 6000W, 220V	Calefactor 6000W, 220V
12	SPPRI342001016	Heating element hole plug	Presse-étoupe du corps de chauffage	Stopfbuchse Heizkörper	Prensaestopas del calefactor
14	SPF01100004514	Ring II	Bague II	Ring II	Corona circular II
18	SPPRI611000051	Front panel tub clamp	Agrafe du front de devant	Schelle Frontteil	Anillo de sujeción de la parte frontal
21	SPPRI231000066	Washer 40x17x6	Cale 40x17x6	Unterlegscheibe 40x17x6	Arandela 40x17x6
22	SPPRI228001007	Nut selfstopping M16	Contre-écrou M16	Mutter M16 selbstsichernd	Tuerca de autoseguridad M16
23	SPPRI202000011	Bolt M6x70	Vis M6x70	Schraube M6x70	Tornillo M6x70
24	SPPRI231002003	Washer 6,4	Cale 6,4	Unterlegscheibe 6,4	Arandela 6,4
26	SPPRI245000004	Washer with external teeth M6	Rondelle à crans multiples du bord externe M6	Fächerscheibe M6	Arandela en abanico M6
27	SPPRI228001007	Nut selfstopping M6	Contre-écrou M6	Mutter M6 selbstsichernd	Tuerca de autoseguridad M6
28	SP525523	Bolt M16x70	Vis M16x70	Schraube M16x70	Tornillo M16x70
29	SP100718	Micro switch	Micro interrupteur	Mikroschalter	Commutador micro
30	SPPRI611000090	Spring	Ressort	Feder	Muelle
31	SPPRI611000091	Spring	Ressort	Feder	Muelle
32	SP100177	Spacer	Rondelle	Ritzel	Espaciador
33	SPPRI523000001	Washer hard	Rondelle	Dichtungsring hart	Arandela de duro
34	SPPRI211000009	Bolt M3x25	Vis M3x25	Schraube M3x25	Tornillo M3x25
35	SPPRI226000001	Nut M3	Ecrou M3	Mutter M3	Tuerca M3
36	SPPRI543000027	Springholder tiltswitch	Fixation ressort interrupteur de balourd	Gehäuse Kippschalter PVC	Soporte muelle interruptor basculante PVC
37	SP509530	Holder of tiltswitch	Support interrupteur de balourd	Unterstützung Kippschalter	Soporte interruptor basculante
38	SPPRI185022015	Steam injector Low pressure 1/2"	Injecteur à vapeur basse pression 1/2"	Dampfinjektor Niederdruckdampf 1/2"	Inyector de vapor baja presión 1/2"
38	SPPRI185021015	Steam injector High pressure 1/2"	Injecteur à vapeur haute pression 1/2"	Dampfinjektor Hochdruckdampf 1/2"	Inyector de vapor alta presión 1/2"
39	SPPRI425000072	Flexible	Tuyau	Dampfschlauch	Manguera
40	SPR22112000114	Double nipple steam 1/2"	Ecrou de raccord 1/2"	Verschraubung 1/2"	Atornillado 1/2"
41	SP514164	Steam valve 1/2" with coil	Soupape à vapeur 1/2" avec bobine	Dampfventil 1/2" mit Spule	Válvula de vapor de 1/2" con bobina
41	SP514165	Steam valve 1/2" without coil, valid for export USA	Soupape à vapeur 1/2" sans bobine, valable pour les USA	Dampfventil 1/2" ohne Spule, gültig für USA	Válvula de vapor de 1/2" sin bobina, válido para EEUU
41	SP514167	Coil, valid for export USA	Bobine, valable pour les USA	Spule, gültig für USA	Bobina, válido para EEUU
42	SP101000	Sealing	Joint	Dichtung	Empaquetadura
43	SP100999	Support steam valve	Support de vanne vapeur	Halter Dampfventil	Sujetador del válvula de vapor
44	SPPRI202000006	Bolt M6x16	Vis M6x16	Schraube M6x16	Tornillo M6x16
45	SPPRI245000004	Washer 6	Cale 6	Unterlegscheibe 6	Arandela 6
46	SPPRI231002003	Washer 6,4x17x3	Cale 6,4x17x3	Unterlegscheibe 6,4x17x3	Arandela 6,4x17x3
47	SP101642	Tilt switch complete	Interrupteur à vibrations, complet	Vibrationsschalter komplett	Interruptor vibratorio completo
48	SPPRI504000031	Outer drum front plate sealing	Garniture d'étanchéité de la face avant du tambour externe	Dichtung Außentrommelstirnseite	Junta de la cara frontal del tambor exterior

ROUND DOOR

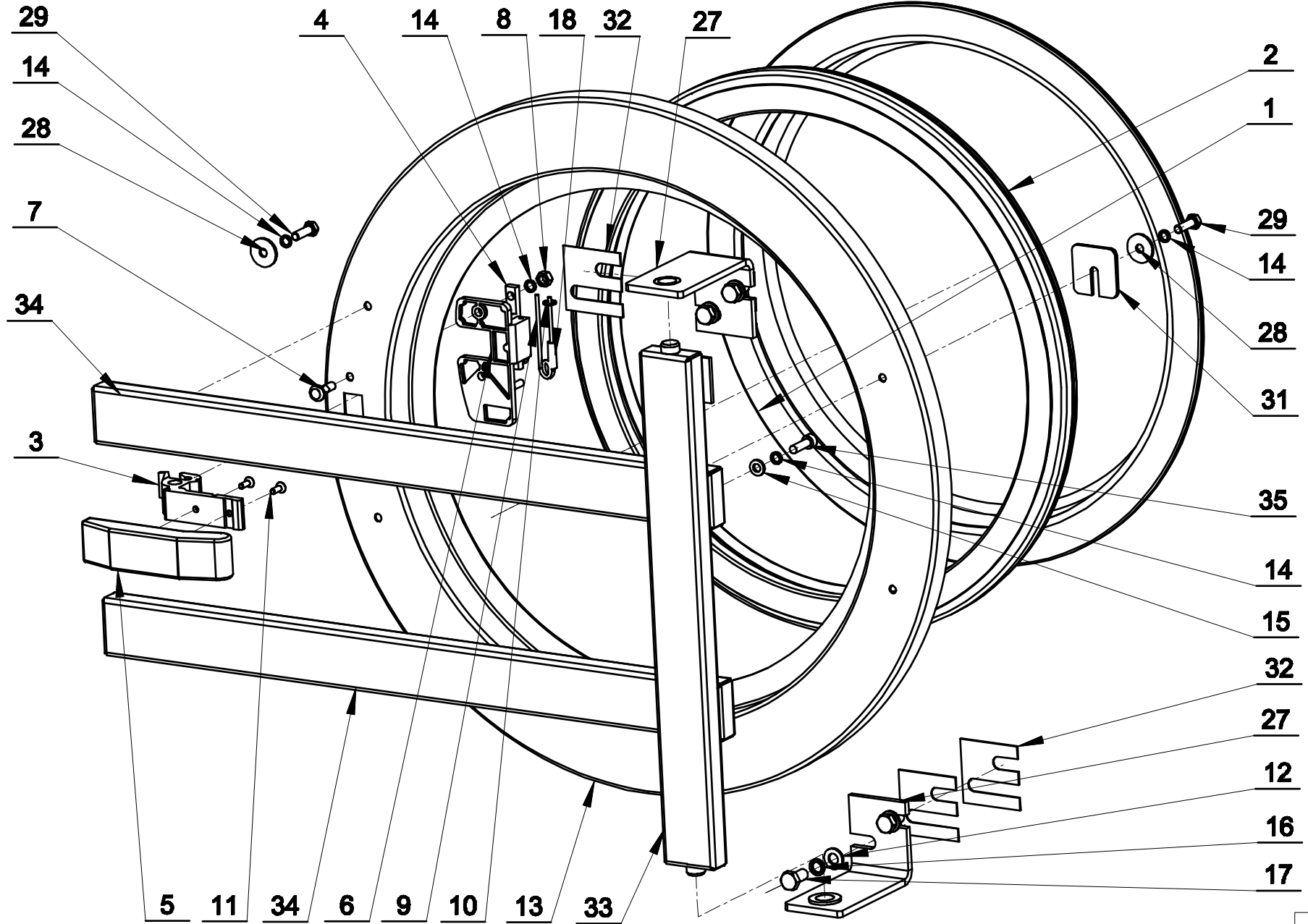

Round door: drawing nr. 507447C

1	SP223107001314	Door glass	Verre	Türglas	Vidrio de la puerta
1	SP223107001324	Door glass, applicable for wet cleaning	Verre, Valable pour le nettoyage humide	Türglas, gültig für nasse Reinigung	Vidrio de la puerta, válido para la limpieza húmeda
2	SP529575	Door glass rubber	Garniture (de joint)	Dichtung Türglas	Empaquetadura del vidrio de la puerta
3	SP100219	Handle lever	Poignée de la manche	Handgriffkurbel	Manivela
4	SPPRI610000089	Handle shaft	Cheville	Bolzen	Fija de la puerta
5	SPPRI610011085	Handle	Manche brillante	Handgriff glänzend	Manivela pulido
6	SPPRI610000082	Handle holder	Plaque suspension	Bandscheibe	Placa de la suspensión
7	SPPRI212000032	Bolt M6x20	Vis M6x20	Schraube M6x20	Tornillo M6x20
8	SP310934240006	Nut M6	Écrou M6	Mutter M6	Tuerca M6
9	SPPRI611000045	Handle spring	Ressort	Schloßfeder	Resorte de la manivela
10	SPPRI247010013	Securing washer	Rondelle de blocage	Sicherungsunterlegscheibe	Arandela de seguridad
11	SP100305	Bolt M4x12	Vis M4x12	Schraube M4x12	Tornillo M4x12
12	SP311125240008	Washer 8,4	Cale 8,4	Unterlegscheibe 8,4	Arandela 8,4
13	SP527397	Door frame			
14	SP311127240006	Washer 6	Rondelle 6	Unterlegscheibe 6	Arandela 6
15	SP311125240006	Washer 6,4	Rondelle 6,4	Unterlegscheibe 6,4	Arandela 6,4
16	SP311127240008	Washer 8	Rondelle 8	Unterlegscheibe 8	Arandela 8
17	SP309933240815	Bolt M8x16	Vis M8x16	Schraube M8x16	Tornillo M8x16
18	SP319300006001	Tube 6x1			
27	SP527904	Hinge complete	Suspension pleine	Türband komplett	Cortina completa
27	SP528586	Upper hinge complete, applicable for wet cleaning	Suspension supérieure pleine	Türband oben komplett	Cortina superior completa
28	SP530884	Washer	Rondelle	Unterlegscheibe	Arandela
29	SP309933240620	Bolt M6x20	Vis M6x20	Schraube M6x20	Tornillo M6x20
31	SP527915	Washer	Rondelle	Unterlegscheibe	Arandela
32	SP529623	Shim			
33	SP527955	Cross beam - welded	Traverse – pièce soudée	Querträger - Schweißteil	Viga - pieza soldada
33	SP528585	Cross beam - welded, applicable for wet cleaning	Traverse – pièce soudée, Valable pour le nettoyage humide	Querträger – Schweißteil, gültig für nasse Reinigung	Viga - pieza soldada, válido para la limpieza húmeda
34	SP527956	Longitudinal beam - welded			
35	SP528549	Bolt M6x20	Vis M6x20	Schraube M6x20	Tornillo M6x20

SQUARE DOOR

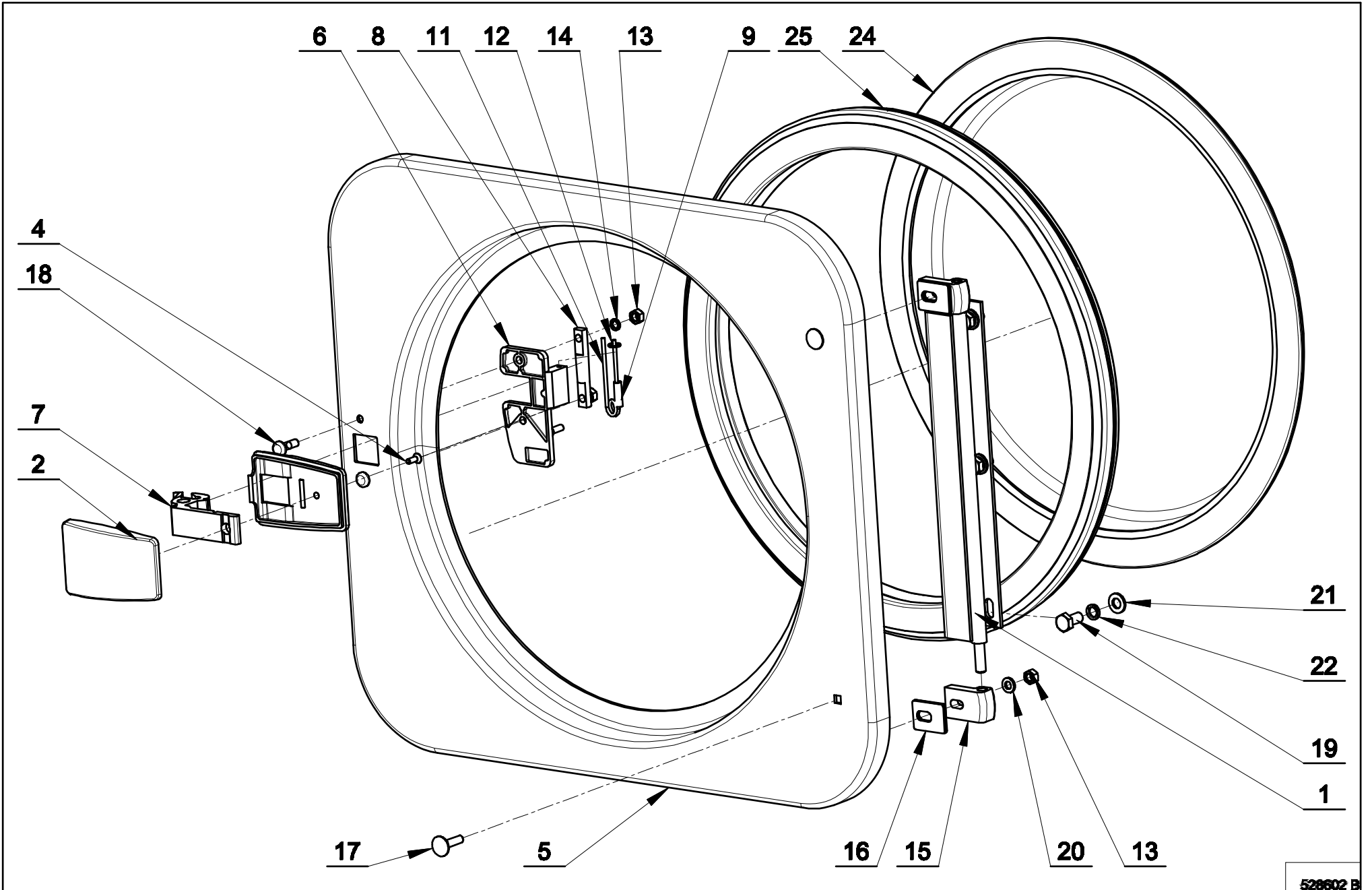

Square door: drawing nr. 528602B

1	SP500193	Hinge complete	Charnière entier	Türband komplett	Fija completo
2	SP510605	Handle - lower part	Manche brillante - Partie inférieure	Handgriff glänzend - Unterteil	Manivela pulido - parte inferior
4	SP100305	Bolt M4x12	Vis M4x12	Schraube M4x12	Tornillo M4x12
5	SP528554	Door	Portière	Tür	Puerta
6	SPPRI610000082	Handle holder	Plaque suspension	Bandscheibe	Placa de la suspensión
7	SP501512	Handle lever	Poignée de la manche	Handgriffkurbel	Manivela
8	SPPRI610000089	Handle shaft	Tourillon	Türbandbolzen	Fija de la puerta
9	SP319300006001	Tube 6x1			
11	SPPRI611000045	Handle spring	Ressort	Schloßfeder	Resorte de la manivela
12	SPPRI247010013	Securing washer	Rondelle de blocage	Sicherungsunterlegscheibe	Arandela de seguridad
13	SP310934240006	Nut M6	Écrou M6	Mutter M6	Tuerca M6
14	SP311127240006	Washer 6	Rondelle 6	Unterlegscheibe 6	Arandela 6
15	SPPRI610000126	Door hinge block	Suspension	Band	Suspensión
16	SPPRI610001122	Fixed side shim	Cale de réglage	Distanzunterlegscheibe	Arandela distanciadora
17	SP516877	Bolt M6x25	Vis M6x25	Schraube M6x25	Tornillo M6x25
18	SPPRI212000032	Bolt M6x20	Vis M6x20	Schraube M6x20	Tornillo M6x20
19	SP309933240815	Bolt M8x15	Vis M8x15	Schraube M8x15	Tornillo M8x15
20	SP311125240006	Washer 6,4	Rondelle 6,4	Unterlegscheibe 6,4	Arandela 6,4
21	SP311125240008	Washer 8,4	Rondelle 8,4	Unterlegscheibe 8,4	Arandela 8,4
22	SP311127240008	Washer 8	Rondelle 8	Unterlegscheibe 8	Arandela 8
24	SP223107001314	Door glass	Verre	Türglas	Vidrio de la puerta
25	SP529575	Door glass rubber	Garniture (de joint)	Dichtung Türglas	Empaquetadura del vidrio de la puerta

TRUNNION

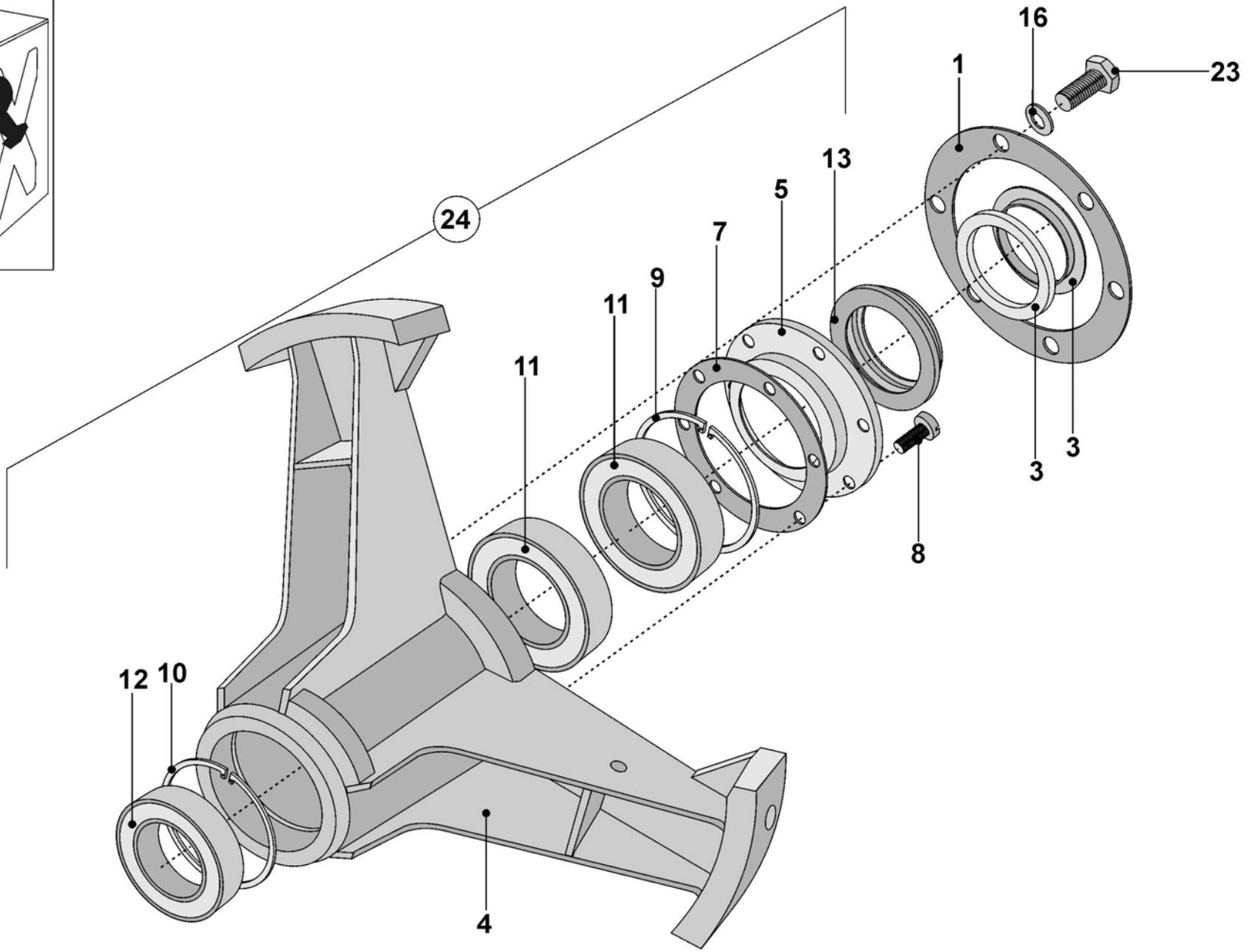
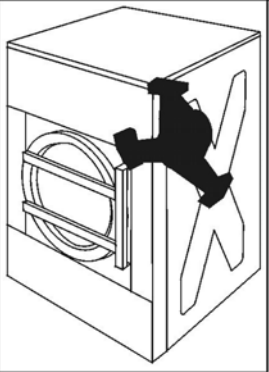

WET CLEANING

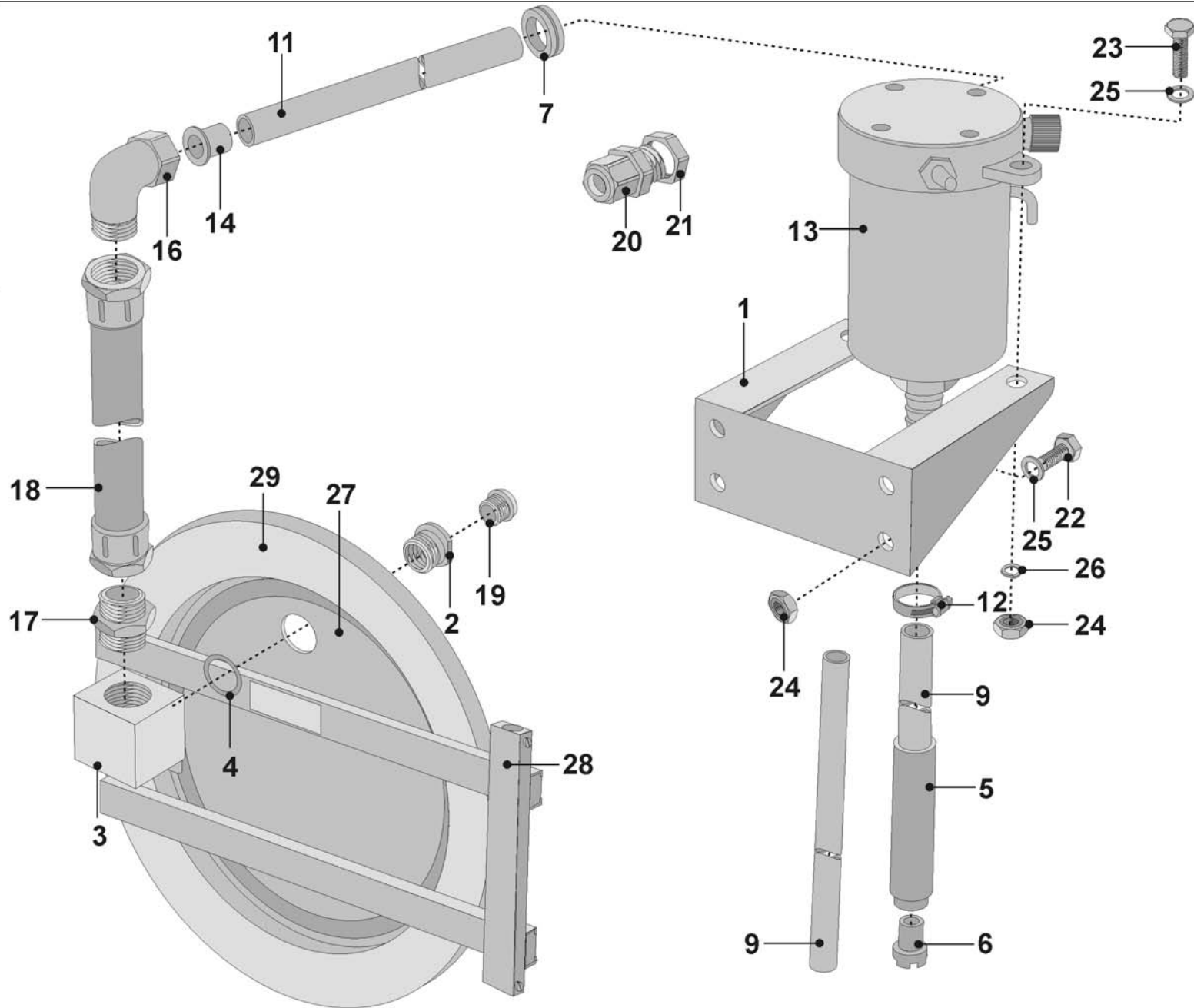
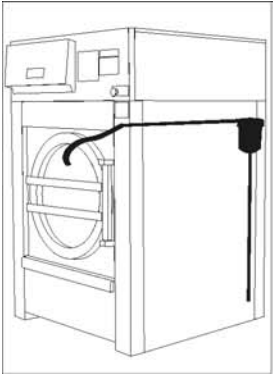

Wet cleaning: drawing nr. 513203

1	SPP0120500011	Pump holder	Support de la pompe	Halter Pumpe	Portabomba
2	SPP0120500021	Shower conection	Ecrou raccord de la buse	Düsenverschraubung	Atornilladura de la tobera
3	SPP0120500031	Shower cube	Cube de la buse	Düsenwürfel	Bloque de la tobera
4	SP273111018002	O-ring 18x2	Bague "O" 18x2	O-Ring 18x2	"O" – anillo 18x2
5	SPPRI406001016	Tube ¾", L=400mm	Tube PVC ¾", L=400mm	PVC-Rohr ¾", L=400mm	PVC tubo ¾" L=400mm
6	SPPRI505001073	Adapter	Manchon de fermeture	Endstück	Adaptador
7	SP273121009001	Cable passage 9x1	Traversée 9x1	Durchführung 9x1	Passo 9x1
9	SPPRI540020005	Hose 10/14-1,1m	Tuyau 10/14-1,5 m	Schlauch 10/14-1,5 m	Manguera 10/14-1,5 m
11	SP283351220111	Hose 6x1-1,5m	Tuyau 6x1-1,5m	Schlauch 6x1-1,5m	Manguera 6x1-1,5m
12	SP540240010016	Clip	Agrafe	Schelle	Borne
13	SPPRI332000030	Pump	Pompe	Pumpe	Bomba
14	SPPRI614000036	Insert piece	Semelle	Einsatz	Pieza de intercalar
16	SPPRI614000038	Elbow 6-M10x1	Ecrou raccord d'angle 6-M10x1	Winkelverschraubung 6-M10x1	Acodadura 6-M10x1
17	SPPRI614000039	Pipe nipple 6-1/8"	Ecrou raccord mamelon 6-1/8"	Einschiebverschraubung 6-1/8"	Entrerrosca 6-1/8"
18	SPPRI505005055	Hose 6-750mm	Tuyau arme 6-750 mm	Schlauch armiert 6-750 mm	Manguera 6-750 mm
19	SP405425000069	Nozzle	Buse	Düse	Inyector
20	SPPRI350001045	Bushing	Presse-étoupe	Kabeldurchführung	Salida de prensaestopas
21	SPPRI350000045	Nut of bushing	Ecrou de la traversée	Mutter Durchführung	Tuerca del paso
22	SP309933000610	Bolt M6x10	Vis M6x10	Schraube M6x10	Tornillo M6x10
23	SP309933000630	Bolt M6x30	Vis M6x30	Schraube M6x30	Tornillo M6x30
24	SP310934100006	Nut M6	Ecrou M6	Mutter M6	Tuerca M6
25	SP311902100006	Washer 6,4/18	Rondelle 6,4/18	Unterlegscheibe 6,4/18	Arandela 6,4/18
26	SP311127000006	Washer 6	Rondelle 6	Unterlegscheibe 6	Arandela 6
27	SP223107001324	Glass-modification (the glass itself)	Verre - adaptation	Anpassung Glas	Cristal-ajuste
28	SP528584	Support of door, adjustment	Support de la portière, adaptation	Türträger, Anpassung	Viga de la puerta, arreglo
29	SP528553	Door complete	Porte complète	Tür komplett	Puerta completa